

# The Galilee Jesus Knew



# The Galilee Jesus Knew

## About the Biblical Archaeology Society

The excitement of archaeology and the  
latest in Bible scholarship since 1974

---

The Biblical Archaeology Society (BAS) was founded in 1974 as a nonprofit, nondenominational, educational organization dedicated to the dissemination of information about archaeology in the Bible lands.

BAS educates the public about archaeology and the Bible through its bi-monthly magazine *Biblical Archaeology Review*, an award-winning web site [www.biblicalarchaeology.org](http://www.biblicalarchaeology.org), and books and multimedia products (DVDs, CD-ROMs and videos). It also sponsors a wide variety of seminars, tours and cruises that bring leading scholars to general audiences.

The articles in this collection were assembled as a service to those planning to visit that country and also to those who want to learn more about this ancient land which is so rich in Biblical history.

### Publishing Excellence

BAS's flagship publication is *Biblical Archaeology Review* (BAR). BAR is the only magazine that connects the academic study of archaeology to a broad general audience eager to understand the world of the Bible. Covering both the Old and New Testaments, BAR presents the latest discoveries and controversies in archaeology with breathtaking photography and informative maps and diagrams. BAR's writers are the top scholars, the leading researchers, the world renowned experts. BAR is the only nonsectarian forum for the discussion of Biblical archaeology.

BAS produced two other publications, *Bible Review* from 1985–2005, and *Archaeology Odyssey* from 1998–2006. The complete editorial contents of all three magazines are available online in the BAS Archive, [www.basarchive.org](http://www.basarchive.org). The BAS Archive also contains the text of five highly-acclaimed books, *Ancient Israel*, *Aspects of Monotheism*, *Feminist Approaches to the Bible*, *The Rise of Ancient Israel* and *The Search for Jesus*. The BAS Archive is available through various colleges, universities, churches and other institutions. Individual users may access the same extensive body of materials in the BAS Library, [www.biblicalarchaeology.org/library](http://www.biblicalarchaeology.org/library).

### Widespread Acclaim

The society, its magazine, and its founder and editor Hershel Shanks have been the subject of widespread acclaim and media attention in publications as diverse as *Time*, *People*, *Civilization*, *U.S. News and World Report*, *The New York Times*, *The Washington Post* and *The Jerusalem Post*. BAS has also been featured on television programs aired by CNN, PBS and the Discovery Channel. To learn more about the Biblical Archaeology Society and subscribe to *Biblical Archaeology Review*, go to [www.biblicalarchaeology.org](http://www.biblicalarchaeology.org).

The articles in this collection originally appeared in *Biblical Archaeology Review* and *Bible Review*.

## Contents

Introduction	1
How Jewish Was Jesus' Galilee? <i>Mark A. Chancey</i>	2
Ports of Galilee: Modern drought reveals harbors from Jesus' time <i>Mendel Nun</i>	14
Why Jesus Went Back to Galilee <i>Jerome Murphy-O'Connor</i>	27
Jesus' Baptism: Three Views	40
Did Jesus Replace John the Baptist?	41
The Galilee Boat—2,000-Year-Old Hull Recovered Intact <i>Shelley Wachsmann</i>	42
Dating the Pottery from the Galilee Boat Excavation <i>David Adan-Bayewitz</i>	60
How Old Is the Galilee Boat? <i>Israel Carmi</i>	61
Synagogue Where Jesus Preached Found at Capernaum <i>James F. Strange and Hershel Shanks</i>	62
Has the House Where Jesus Stayed in Capernaum Been Found?: Italian archaeologists believe they have uncovered St. Peter's home <i>James F. Strange and Hershel Shanks</i>	73
How to Read the Plans	88

INTRODUCTION

---

## Galilee

**G**alilee is one of the most evocative locales in the New Testament—the area where Jesus was raised, where many of the Apostles came from, and where Jesus first began to preach. We’ve selected a number of articles to widen your knowledge of this important region, focusing on how Jewish the area was in Jesus’ time, on the ports and the fishing industry that was so central to the region, and on several sites where Jesus likely stayed and preached.

## How Jewish Was Jesus' Galilee?

By Mark A. Chancey

---

**T**he pendulum is beginning to swing back again. Before 20th-century archaeologists began uncovering it, Jesus' Galilee was generally considered rural Jewish terrain. Then archaeologists made some astounding finds. Excavations at Sepphoris, less than 4 miles from Jesus' hometown of Nazareth, revealed inscriptions in Greek, Roman architecture and some breathtaking Greco-Roman art, including the famous mosaic dubbed by excavator Carol Meyers the "Mona Lisa of the Galilee." The "Mona Lisa" was part of a larger mosaic depicting a *symposium* (a dinner with ample alcohol) with the mythological hero Hercules and the god of wine, Dionysus, as guests.

Digs at other sites in Galilee uncovered similar finds. The scholarly community was surprised, impressed and excited, and naturally sought to incorporate this new information into their reconstructions of Jesus' Galilee. Some scholars argued that Greek complemented Aramaic as a language of daily use in

Galilee, that Greco-Roman architecture dotted the landscape and that artistic depictions of emperors, deities and mythological heroes were common.

A Roman-style theater at Sepphoris raised the intriguing hypothesis that Jesus had actually attended it, watching classical dramas and comedies.<sup>a</sup>

Jesus was soon compared to Cynic philosophers, those wandering counter-cultural preachers found in many cities of the Roman empire.

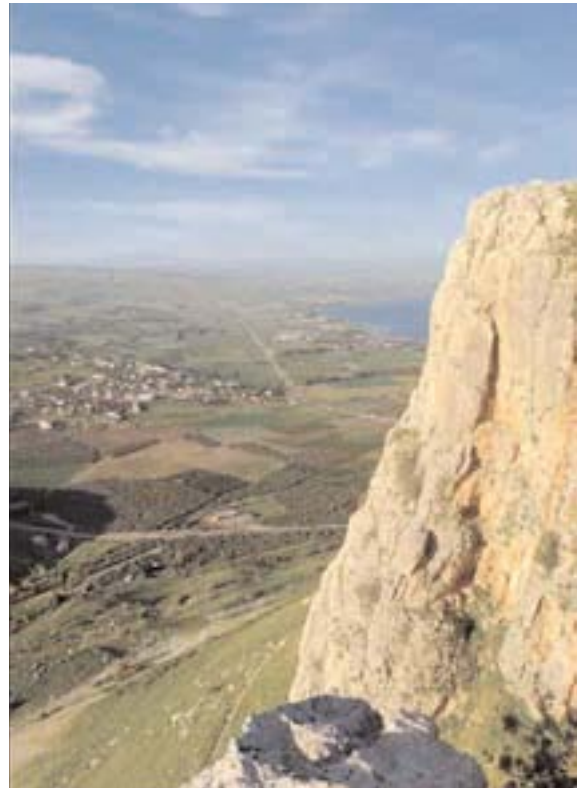

Todd Bolen/www.bibleplaces.com

David Hendin



*NO GRAVEN IMAGES.* The coins from the reign of Herod Antipas have Greek inscriptions, but depict no living beings so as not to offend the sensibilities of the Jewish population. The coin shown here was struck during the 24th year of his reign, or 20 C.E. It shows a reed upright with the date on the obverse and an inscription reading "Tiberias" surrounded by a wreath on the reverse.

Some studies proposed that in Jesus' time, many Galileans were gentiles, whether Greeks, Romans, Phoenicians, Arabs or others.

Now, however, as more detailed publication of archaeological finds have made more systematic study possible, many of these views are being questioned. The pendulum is swinging back—at least a little. Few would dispute that Greco-Roman culture was certainly a part of Galilean life in Jesus' time, but it is important to put this into perspective. The region's cultural milieu must be dated very carefully, for it changed quite considerably from period to period. In short, in Jesus' time it was not so permeated by Greco-Roman culture as some scholars have previously proposed. Much of the archaeological evidence most widely relied upon reflects the Galilee not of the early first century C.E., but rather the Galilee of the second, third and fourth centuries C.E.

David Hendin



To understand the growth of Greco-Roman culture in Galilee, we must trace its historical development. By Jesus' time, Galilee's encounter with Hellenism (Greek culture) was centuries old, going back to the age of Alexander the Great, the Macedonian king who conquered Palestine and much of the rest of the Near East during his brief reign (c.336–323 B.C.E.).

On Alexander's death his kingdom was divided between the Ptolemies in Egypt and the south, on the one hand, and the Seleucids in the north, on the other. Palestine, in the middle, often changed hands between the dueling dynasties. In the second century B.C.E., the Jewish Hasmonean dynasty—they of the Maccabees—ruled an independent Jewish kingdom, but the Hasmoneans turned out to be very devoted to Hellenistic culture as well.

In 63 B.C.E. Pompey interceded militarily to quell a Hasmonean conflict, thus ending the independent Jewish kingdom and bringing direct Roman rule to Palestine. Naturally the Romans brought with them their own culture. The mixture of Hellenistic and Roman influence came to be known, naturally enough, as Greco-Roman culture.

In 40 B.C.E. the Romans installed a new king over the Jews of Palestine, Herod the Great. Herod is known from the New Testament as ordering the massacre of all the male infants in Bethlehem in hope of killing the baby Jesus (Matthew 2:16–18). Herod was a devoted and loyal patron of Greco-Roman culture not only in Palestine, but in the entire eastern Mediterranean world. Even outside his own territory, he sponsored numerous major building projects like gymnasia at Tripoli, Damascus and Ptolemais and theaters at Sidon and Damascus.<sup>1</sup> In Palestine he built two cities: Sebaste, on the site of Biblical Samaria, and Caesarea Maritima, his showcase port. Both cities had streets aligned on a grid, intersecting at right angles, which was characteristic of Greco-Roman cities. Caesarea Maritima boasted of agoras, an amphitheater (a round or oval theater for animal shows and combat sports), an aqueduct and a theater; all typical features of Greco-Roman culture.<sup>b</sup>



Eric Meyers/Sepphoris Regional Project

*DRINK AND BE MERRY.* After an apparently extended bout of drinking with Dionysus, the god of wine, an inebriated Hercules is aided by a maenad and a satyr. His club rests beside him and the Greek word for “drunkenness” appears above the shoulder of the satyr. This depiction of an ancient **symposium** is part of a larger mosaic floor of the third-century C.E. villa at Sepphoris.

The freely depicted graven images suggest that, by the late second and early third centuries, the population of Sepphoris included a significant number of gentiles. No such images have been found in these areas from the earlier time of Jesus.

In Caesarea Maritima, Sebaste and Caesarea Philippi, Herod built temples to the emperor Augustus and Roma, goddess of the city of Rome (as well as rebuilding the Jewish Temple in Jerusalem).

Herod’s largesse, however, does not seem to have extended to Galilee. Through the death of Herod the Great in 4 B.C.E., communities in Galilee appear to have remained without Greco-Roman architecture.

On his death, Herod’s kingdom was divided. To his son Antipas (or Herod Antipas, also called “Herod” in the Gospels)<sup>2</sup> went Galilee. Antipas’s rule lasted until 39 C.E., thus covering the life of Jesus.

Though his father had neglected the region, it was the center of Antipas’s attention. He renamed Sepphoris Autocratoris, a name that honored the Roman emperor, whose Latin title of *Imperator* was translated into Greek as *Autocrator*.<sup>c3</sup> At least some of the





city's streets were built on a grid pattern during his reign. The foundations of a basilical building—a rectangular, columned structure often used as a sort of “city hall” in Roman cities—may also date to his reign, as does one of the aqueduct systems.<sup>d</sup> Some scholars (James F. Strange and Richard A. Batey) have dated Sepphoris's 4,500-person theater to Antipas's reign on the basis of pottery fragments discovered underneath the theater. Others (Carol and Eric Meyers, Zeev Weiss and Ehud Netzer) date this pottery and thus the theater above it to the late first or early second century C.E., after the crucifixion.<sup>4</sup> It is not yet clear whether a theater existed in Sepphoris that Jesus might have attended.

Marty Cooper



Everyone agrees, however, that at the end of the first century, a period of extensive growth began in Sepphoris that continued for centuries. The grid pattern of the city's streets became even more pronounced, and a new aqueduct system (the one featured prominently in the modern park) was constructed, as were two Roman-style bathhouses.

As indicative as this is of Greco-Roman culture, it is also important to note what was not in the Galilee, although common in other areas of the

*All the world's a stage, but did Jesus ever see a play at the Sepphoris theater? Jesus often admonished his followers to be unlike the **hypocrites** (Matthew 6:2, 5), a word that originally meant “one acting on the stage.” It has been suggested that Jesus learned the word by attending stage presentations at Sepphoris, only 4 miles from Nazareth, where Jesus grew up. Herod Antipas completely rebuilt Sepphoris in the early first century as the crown and capital of his kingdom to compete with the grandeur of Rome after the death of his father, Herod the Great. Some scholars argue that Antipas would surely have included a theater in this project and date the 4,000-seat theater to Jesus' time based on pottery found underneath it. Other archaeologists believe that the theater was built decades after the crucifixion of Jesus.*

Roman East at this time: no amphitheater, no gymnasium, no stadium and no nymphaeum (a large, elaborately decorated fountain).

The other major city in the Galilee (after Sepphoris) built by Antipas was Tiberias on the southwestern shore of the lake. Antipas founded it in about 20 C.E. and named it after the then-reigning Roman emperor, Tiberius (14–37 C.E.). The city underwent extensive growth in subsequent centuries, and the overlay of the modern resort city limits the area of potential excavation. Perhaps for these reasons, little has been recovered in modern excavations from the time of Antipas—and thus of Jesus as well. The Jewish historian Josephus refers to a sports stadium in Tiberias at the time of the First Jewish Revolt against Rome (66–70 C.E.),<sup>5</sup> and archaeologists may have found this structure.<sup>6</sup> As at Sepphoris, however, archaeologists have uncovered much Greco-Roman construction from later periods: a *cardo* (the main north-south street of Roman cities) in the second century; a theater in the second or third; and a bathhouse in the fourth.

At other Galilean sites, structures reflecting Greco-Roman culture veritably abound, but little if anything is from the first half of the first century. Roman-style bathhouses were found at Capernaum from the second or third century.<sup>e</sup> At the northern site of Rama, similar structures were found from the third or fourth century.<sup>7</sup> The situation is similar even with regard to synagogues. Synagogues from the fourth century onward reflect strong Greco-Roman architectural influence, as seen, for example, in their rectangular layouts and use of columns.

Communities near Galilee experienced similar developments. Scythopolis (Beth Shean), for example, on the southeastern border of Galilee, had an amphitheater, a bathhouse, a palaestra, a temple and possibly a nymphaeum—but all from the second century or later.<sup>f</sup>



Hershel Shanks

*The great wings beating still, Zeus in the form of a swan comes to Leda and leaves her with child in this carving on a third- or fourth-century C.E. sarcophagus from the Jewish burial vaults at Beth She'arim. Artistic representations of animal and human figures can be found throughout the Galilee even in Jewish areas, but from after the time of Jesus. The decorations and artifacts that have been found in the region contemporaneous with Jesus are simple and generally do not depict living things.*

Zev Radovan



*FROM THE TIBERIAS MINT.* The coin shown depicts a bust of the emperor Hadrian, with a Roman boat and the word "Tiberias" on the reverse and dates from about 120 C.E. By the second century, the coins of the Galilee looked like coins from anywhere else in the Roman empire, but during the time of Jesus they were designed not to offend Jewish sensibilities.

Zev Radovan



The same chronological development we have seen with respect to Galilean architecture may also be observed in the visual arts—frescoes, mosaics, statues, figurines and funerary art. The interior walls of some first-century buildings were painted with geometric patterns: dots, lines and blocks of color. On the floors were some simple mosaics, often of only black and white tesserae. Compare these rather basic decorations with the early-third-century Dionysus mosaic that included not only the Mona Lisa of the Galilee, but also panels depicting Dionysus (the Greek god of wine), his worshipers and entourage, and the mythical Hercules. Another panel portrays the wedding of Dionysus to Ariadne. Still another depicts bearers bringing gifts to the god. The mosaic is one of the highest quality found anywhere in Roman Palestine.<sup>8</sup> But it dates long after Jesus' time.

Sharaga Gedar



Other finds at Sepphoris from the second century and later likewise reflect an increasing comfort level with artistic depictions of humans, animals and deities, such as bronze figurines of Pan and Prometheus. Although not entirely absent in first-century Galilee, such depictions are quite rare, presumably because of Jewish prohibitions of representational art.

The same chronological development in visual art can be seen elsewhere in Galilee as well. At the Jewish burial complex at Beth She'arim, where Rabbi Judah ha-Nasi, the revered compiler of the Mishnah (the core of the Talmud) was buried, we find sarcophagi that bear carvings of animals, people and even

*"In the 34th year of Herod" reads the only inscription (aside from coins) yet found in the Galilee that dates to the lifetime of Jesus. In later years the frequency of inscriptions greatly increases, with Greek examples outnumbering those in Hebrew or Aramaic.*



*IMPERVIOUS TO IMPURITY.* In the miracle at Cana, Jesus turned water into wine. The water was in “six stone jars [of water] for the Jewish rites of purification” (John 2:6). Stone vessels are a telltale sign of a predominantly Jewish population, because, unlike clay vessels, stone vessels are not subject to impurity. First-century C.E. fragments were found in the residential quarter at Sepphoris. Stone vessels such as these are rarely found at sites known to have been inhabited by gentiles but have been found at 23 sites throughout the Galilee. When whole, the stone vessels would have looked like the jars pictured here found in Jerusalem.

mythological figures, like Leda and the Swan (Zeus in the form of a swan impregnated Leda).<sup>8</sup> But all this is from the third and fourth centuries.

Coins aside, only one inscription from the lifetime of Jesus (the first 30 or so years of the first century) has been excavated in Galilee: a market weight from Tiberias with a Greek inscription reading “In the 34th year of Herod the Tetrarch, during the term of office as market overseer of Gaius Julius...”<sup>9</sup> Few inscriptions date even to later decades of the first century: A Greek inscription of an imperial edict prohibiting tomb robbery probably dates to 44 C.E. or shortly thereafter.<sup>10</sup> Another Greek market weight<sup>11</sup> and a Semitic ostrakon (a pottery fragment with writing on it) from Yodefat bear inscriptions too fragmentary to reconstruct.<sup>12</sup>

In later centuries, the number of inscriptions vastly increases. Several examples have been found at Sepphoris, including a mid-second-century Greek market weight.<sup>13</sup> Greek inscriptions are also contained in the Dionysus mosaic mentioned earlier. Nearly 280 inscriptions from the late second through the early fourth centuries were found at Beth She’arim (approximately 80 percent in Greek, 16 percent in Hebrew, and the rest in Aramaic or Palmyrene).<sup>14</sup> Latin (and in a few cases, Greek) inscriptions are found on the milestones of Roman roads. The chronological pattern is striking: The later the date, the more likely the inscription is to be in Greek.

Coins with images and inscriptions, however, are an exception to this chronological development. Old Hasmonean coins from as early as the second century B.C.E. were still circulating in the early first century C.E. Some indeed had Semitic inscriptions, but others had Greek inscriptions. Many bore common numismatic images such as cornucopias and plants. Coins struck in pagan cities or by imperial Roman mints naturally had Greek inscriptions and freely depicted living things. A portrait of the Roman emperor was also common on these coins. But until the time of Antipas, no coins were

actually struck in Galilee. True, Antipas's coins did contain Greek inscriptions, but this was more a reflection of his desire to conform to the coinage customs of the larger Roman East. In his choice of language, Antipas wanted his coins to blend in, not stand out. He did not, however, depict living things—no gods, animals or portraits of the emperor. Instead, his coins usually depicted a plant, such as a palm tree.

Todd Bolten/www.bibleplaces.com



Ritual baths such as this first-century **mikveh** found at Gamla, a community in the nearby Golan east of the Galilee, also attest to a Jewish population. Immersion in a **mikveh** removes impurity. **Mikva'ot** have been found at Yodefat, Sepphoris and other sites throughout Jewish Galilee.

When the cities of Sepphoris and Tiberias struck coins later in the first century, they, too, avoided depictions of living things. Not until the second and third century did Galilean coins portray images of the emperor or deities. A coin struck in Tiberias during Hadrian's reign (second century C.E.), for example, depicted the emperor on one side and Zeus seated in a temple on the other.<sup>15</sup> In this way, Galilee coins became virtually indistinguishable from those elsewhere in the Roman East.

cultural climate in flux. It was not totally isolated from the architectural, artistic and linguistic trends of the larger Greco-Roman world, but neither had it fully incorporated them into its own culture. In the time of Jesus, we see what amount to hints of what would come in subsequent centuries.

The conclusion is clear: During the early first century C.E., when Jesus lived in Galilee, it was hardly infused with Greco-Roman influence. Instead we should look at it as a region with a

Another similar and related question arises: What about the people living in the Galilee? Were they Jewish or Greek? The answer is somewhat like the cultural mix: Mostly Jewish, but a few gentiles as well.

This is the situation reflected in the ancient sources that have survived: the Gospels, the histories of Josephus and the writings of the rabbis. They mention *some* gentile Galileans, but few. Josephus, for example, reports that at the outbreak of the First Jewish Revolt against Rome (66–70 C.E.), certain Jews in Tiberias attacked the city's gentile minority.<sup>16</sup> Similarly Matthew 8:5–13 and Luke 7:1–10 mention a gentile centurion (probably an officer in the army of Antipas, rather than a Roman soldier) at Capernaum. But none of the sources gives the impression that gentiles formed an especially significant proportion of Galilee's population.

The archaeological situation confirms this impression. There are three kinds of archaeological indicators that inhabitants of a settlement were Jewish: limestone vessels, ritual baths (*mikva'ot*) and ossuaries.



Gods of the pagan pantheon decorate artifacts of towns surrounding the Galilee. A bulla from the northern village of Kedesh (dating to about 200 B.C.) shows Apollo, the god of archery, with the string of his bow drawn at the ready. However, no pagan artifacts or inscriptions have been found inside Galilee dating to Jesus' time.

Most pots and dishes in the ancient world were made of clay. But Jews in Jesus' time also used unusual limestone vessels (also known as chalk vessels).<sup>h</sup> According to the rabbis, limestone vessels played a special role in the Jewish purity system, because they were believed to be impervious to impurity.<sup>17</sup> Storing liquids in these vessels helped safeguard the contents from becoming ritually unclean. This is illustrated in the famous story in the Gospel of John about the wedding at the Galilean village of Cana: According to John 2:1–11, Jesus and his disciples were guests at the wedding; as the celebration progressed, the hosts ran out of wine. Nearby, however, were “six [empty] stone water jars for the Jewish rites of purification, each holding twenty or thirty gallons.” Jesus told the host's servants to fill the jars with water; when they did so, the water miraculously turned to wine.

Limestone vessels were made in a variety of forms, sometimes carved by hand, sometimes on a lathe and sometimes both ways. They include mugs (often erroneously described as “measuring cups”), bowls and storage jars in various sizes.

Because the use of these stone vessels as Jewish is so well attested in literary sources and since they are rarely found at sites known to have been predominantly gentile, their discovery at a particular site is strong evidence of Jewish habitation. Stone vessels or fragments of such vessels have been found at 23 sites in and near Galilee.

*Mikva'ot*—plastered, stepped pools carved into bedrock used by Jews as ritual baths to remove impurity—have been discovered in first-century C.E. strata at Sepphoris and Yodefat. Additional *mikva'ot* appear at numerous other Galilean sites between 63 B.C.E. (the beginning of direct



Secondary burial was common among the Jews at the end of the Second Temple period. About a year after death, when the body had decayed, the bones were reinterred in a bone box called an ossuary. This first-century C.E. limestone ossuary was found in a vaulted mausoleum in the Qiryat Shemu'el section of modern Tiberias. Ossuaries are a clear sign of Jewish habitation.

Roman rule) and 135 C.E. (the end of the Second, or Bar-Kokhba, Jewish Revolt). A *mikveh* from the first century C.E. was also found at Gamla, a Jewish community east of Galilee.<sup>i</sup> All this is indicative of Jewish habitation.

The final ethnic indicator comes from Jewish burial practices. Many Jews—but not gentiles—observed a custom called secondary burial. About a year after burial, when the flesh had desiccated, the deceased’s bones were gathered up and reburied, usually in an ossuary, a small sarcophagus. Regular readers of **BAR** are very familiar with ossuaries because of the controversy generated by the discovery of an ossuary with an inscription on it that some scholars have argued refers to James the brother of Jesus.<sup>j</sup> Jews began practicing secondary burial in Judea in the late first century B.C.E. These ossuaries are usually made of limestone, though some are made of clay. Exactly when Galilean Jews adopted the practice of second burial is uncertain. There is ample evidence of the practice in Galilee soon after the First Jewish Revolt (66–70 C.E.). It is likely that the custom predates the revolt, however, although the evidence is still somewhat unclear. To be strictly accurate, secondary burial has been attested at a number of Galilean sites in Early Roman (63 B.C.E.–135 C.E.) and later archaeological strata.

What about archaeological evidence for gentiles in Galilee? There simply isn’t much, at least during the first century C.E. Inscriptions reflecting the worship of pagan gods are found at the border of Galilee, but not the interior. There are no Galilean statues of gods or goddesses. Figurines of deities are likewise few and far between. Nor have archaeologists found any first-century pagan temples in Galilee, though some point to a structure just across the Galilean border, at et-Tell (possibly Biblical Bethsaida), as a possibility.<sup>k</sup>

In short, we can conclude that Galilee was predominantly Jewish during Jesus’ lifetime. Most of the areas around it, however, were predominantly gentile. For example, pagan Scythopolis was especially close, as were the pagan cities of Hippos, Caesarea Philippi, and the village of Kedesh in the north. It was on the other side of the Sea of Galilee, the eastern side, for example, that Jesus cured the demoniac(s) by sending the demons into a herd of swine who then ran into the sea and drowned (Matthew 8:28–34; Mark 5:1–20; Luke 8:26–39). The swine would not be seen in a Jewish area.

In Jesus’ time, Jewish Galilee had indeed been influenced by some Greco-Roman culture, but only later periods would see that influence flower. And in Jesus’ time the Galilee was largely a Jewish enclave.

## Notes

- a. Richard A. Batey, “Sepphoris: An Urban Portrait of Jesus,” **BAR** 18:03.
- b. See Robert J. Bull, “Caesarea Maritima: The Search for Herod’s City,” **BAR** 08:03; Barbara Burrell, Kathryn Gleason and Ehud Netzer, “Uncovering Herod’s Seaside Palace,” **BAR** 19:03.

- c. See Mark Chancey and Eric M. Meyers, “How Jewish Was Sepphoris in Jesus’ Time?” **BAR** 26:04.
  - d. See Chancey and Meyers, “How Jewish Was Sepphoris?”
  - e. See John C. H. Laughlin, “Capernaum: From Jesus’ Time and After,” **BAR** 19:05.
  - f. See “Glorious Beth-Shean,” **BAR**, 16:04.
  - g. See “Beth She’arim: Vast Underground Burial Caves Show Synergism of Greek Art with Jewish Tradition,” **BAR** 18:05.
  - h. See Yitzhak Magen, “Ancient Israel’s Stone Age: Purity in Second Temple Times,” **BAR** 24:05.
  - i. As to some of these alleged *mikva’ot*, there is fierce academic debate. Hanan Eshel, for example, argues that some of the pools at Sepphoris cannot be *mikva’ot* because they do not match later rabbinic descriptions of such baths. In his view, their small size, lack of a partition in the steps leading into the pool, and absence of a storage tank for water suggest that the pools were used for purposes other than removing impurity. Perhaps, he suggests, they were used for regular hygienic bathing. Hanan Eshel, “They’re Not Ritual Baths,” **BAR** 26:04. Most scholars note, however, that rabbinic opinions do not yet appear to have been authoritative as early as the first century. They also point out that if such pools were used for regular baths, we would expect to find them at a far greater range of sites, including those that were predominantly gentile. Eric M. Meyers, “Yes, They Are,” **BAR** 26:04; Ronny Reich, “They Are Ritual Baths,” **BAR** 28:02. In my opinion, it is far more likely that these pools are, indeed, *mikva’ot*.
  - j. See André Lemaire, “Burial Box of James the Brother of Jesus,” **BAR** 28:06; Edward J. Keall, Hershel Shanks, “Is It or Isn’t It?” **BAR** 27:06; “Brother of Jesus’ Ossuary—New Tests Bolster Case for Authenticity,” **BAR** 29:04; [www.biblicalarchaeology.com/James Ossuary](http://www.biblicalarchaeology.com/James-Ossuary).
  - k. See Rami Aray, Richard A. Freund and John F. Shroder Jr., “Bethsaida Rediscovered,” **BAR** 26:01, which rejects the identification of et-Tell as Bethsaida.
1. Josephus, *Jewish Antiquities* 16.146–148; *Jewish War* 1.422–425 (Loeb ed.).
  2. See, for example, Mark 6:14–29; Luke 3:1, 23:7–12.
  3. See the sources cited in Mark A. Chancey, *The Myth of a Gentile Galilee*, Society for New Testament Studies Monograph Series 118 (Cambridge: Cambridge Univ. Press, 2002), pp. 69–83.
  4. James F. Strange, “Six Campaigns at Sepphoris: The University of South Florida Excavations, 1983–1989,” in Lee I. Levine, ed., *The Galilee in Late Antiquity* (New York and Jerusalem: The Jewish Theological Seminary of America, 1992), pp. 339–356; Carol Meyers and Eric M. Meyers, “Sepphoris,” *Oxford Encyclopedia of the Ancient Near East*, vol. 4, (New York and Oxford: Oxford Univ. Press, 1997), pp. 527–536; and Zeev Weiss and Ehud Netzer, “Hellenistic and Roman Sepphoris: The Archaeological Evidence,” in Rebecca Martin Nagy, Carol L. Meyers, Eric M. Meyers, and Zeev Weiss, *Sepphoris in Galilee: Crosscurrents of Culture* (Winona Lake, IN: Eisenbrauns, 1996), pp. 29–37.
  5. Josephus, *Jewish War* 2.618 and 3.539–540.
  6. “Roman Stadium Found in Tiberias,” *Jerusalem Post*, June 17, 2002.
  7. Vassilios Tzaferis, “A Roman Bath at Rama,” *Atiqot* 14 (1980), pp. 66–75.
  8. Carol L. Meyers, Eric M. Meyers, Ehud Netzer and Zeev Weiss, “The Dionysos Mosaic,” in Nagy et al., *Sepphoris in Galilee*, pp. 111–116; R. Talgam and Z. Weiss, *The Mosaics of the House of Dionysos at Sepphoris* (Jerusalem: Institute of Archaeology, Hebrew Univ., 2004).



9. Shraga Qedar, "Two Lead Weights of Herod Antipas and Agrippa II and the Early History of Tiberias," *Israel Numismatic Journal* 9 (1986–1987), pp. 29–35.
10. Eric M. Meyers and James F. Strange, *Archaeology, the Rabbis, and Early Christianity* (Nashville: Abingdon, 1981), pp. 83–84.
11. Qedar, "Two Lead Weights of Herod Antipas and Agrippa II and the Early History of Tiberias," pp. 29–35.
12. David Adan-Bayewitz and Mordechai Aviam, "Iotapata, Josephus, and the Siege of 67: Preliminary Report on the 1992–1994 Seasons," *Journal of Roman Archaeology* 10 (1997), pp. 131–165, esp. p. 152.
13. See comments by Meshorer in Nagy et al., *Sepphoris in Galilee*, p. 201.
14. The statistics are from Lee I. Levine, "Beth She'arim," *Oxford Encyclopedia of Archaeology of the Near East*, vol. 2, pp. 309–311.
15. Yaakov Meshorer, *City—Coins of Eretz—Israel and the Decapolis in the Roman Period* (Jerusalem: Israel Museum, 1985), p. 34.
16. Josephus, *Life*, 65–67.
17. *Mishnah Kelim* 10.1; *Mishnah Oholoth* 5.5; *Mishnah Yadayim* 1.2.

## Ports of Galilee

Modern drought reveals harbors from Jesus' time

By Mendel Nun

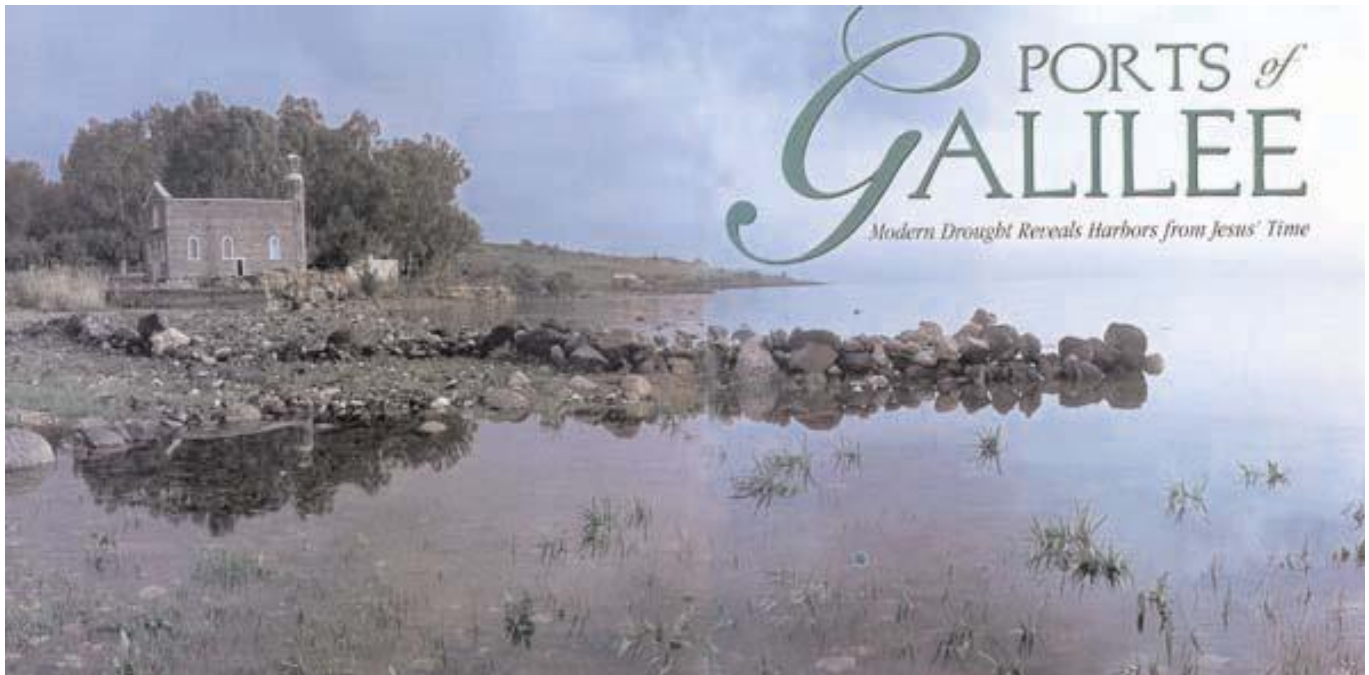

Garo Nalbandian

*The waters of the Sea of Galilee have risen since ancient times, and the remains of most of the harbors are usually underwater. But when the waters recede, author Mendel Nun scours the shore, searching for the tell-tale remains of ancient ports. In this photograph, a line of basalt boulders juts into the waters at Tabgha, where Peter and Andrew once fished. A small stone church commemorates the site where, according to tradition, Jesus called to his first disciples: "Follow me and I will make you fishers of men" (Mark 1:17; Matthew 4:19).*

**E**arly 19th-century explorers, searching for places where Jesus had walked, attempted to locate the ancient harbors of the Sea of Galilee but failed. Now, after 25 years of searching and researching, we have found them. We have recovered the piers, promenades and breakwaters of the ports. We have also uncovered the ships' anchors, the mooring stones the sailors tied their ships to, and even the weights fishermen once fastened to their nets. We always knew the harbors must be there, but we had no idea we would find so many remains.

Garo Nalbandian



*Sailor's delight. The still of evening falls on the Sea of Galilee, bringing a calm that belies the activity the sea has seen throughout the centuries. In Jesus' time, the fishing industry flourished here, and at least 15 man-made harbors dotted the shores of the sea, known in Hebrew as the Kinneret.*

large modern fishing vessels and several small fishing boats. In ancient times, however, at least 16 bustling ports provided the basic means of communication and transport for travelers, fishermen, traders and thousands of residents living beside the small sea (about 14 miles from north to south and 8 miles across).

Ancient literary sources—the New Testament, the writings of the first-century C.E. Jewish historian Josephus, and rabbinic literature such as the Talmud—suggest that two thousand years ago hundreds of vessels plied the waters of Israel's only freshwater lake (and the world's lowest, at 700 feet below sea level). But even though all these sources refer to fishing and boating, not one mentions the harbors that were on the lake during the Hellenistic, Roman and Byzantine periods (332 B.C.E.–630 C.E.). Perhaps ancient historians did not mention them because they took them for granted.



Zev Redovan

*A Roman war vessel appears on a second-century C.E. coin from Gadara, which lay 5 miles southeast of the Sea of Galilee. Other coins from Gadara commemorate the Naumachia—Roman naval games believed to have been performed at the Tel Samra harbor, which served the residents of Gadara. The unusually long breakwater at Tel Samra may have accommodated hundreds of spectators gathered to watch the mock battles.*

Today the remains of the harbors are merely layers of stone foundations, easily recognized by the practiced eye. Most are made of black basalt, the volcanic rock that abounds in this area. From these unimpressive remains, we can picture the Sea of Galilee in Jesus' time in a way that would have been impossible just a few years ago.

The construction of the harbors required organizational skill and economic planning. Breakwaters were built first, followed by piers and promenades, repair shops for boats, administrative buildings, storehouses, tollhouses, watchtowers and other facilities. Maintenance was, of course, necessary, and the breakwaters were continually repaired and silt removed.

The first ancient harbor we discovered was the eastern Galilee site of Kursi (Biblical Gergesa), where, according to the Gospels, Jesus landed after stilling a storm on the sea. As Jesus stepped out on land, he was met by a man possessed by demons. Jesus ordered the demons to leave the man, and they entered a herd of swine, which rushed down the steep slope into the lake and drowned (Luke 8:22–39//Mark 5:1–20//Matthew 8:28–32). According to early Christian tradition, all this occurred at Kursi.<sup>a</sup>

During the 1970 excavation of the ancient church and monastery that commemorate the miracle of the swine, the surrounding area was surveyed. Since the water level of the sea was high that year, an underwater research team headed by Avner Raban investigated the shoreline, where the breakwater of the ancient harbor was discovered.

An essential element of any Galilee port is the stone wall of the breakwater, which extends into the sea from the shore and curves around the harbor to protect the boats

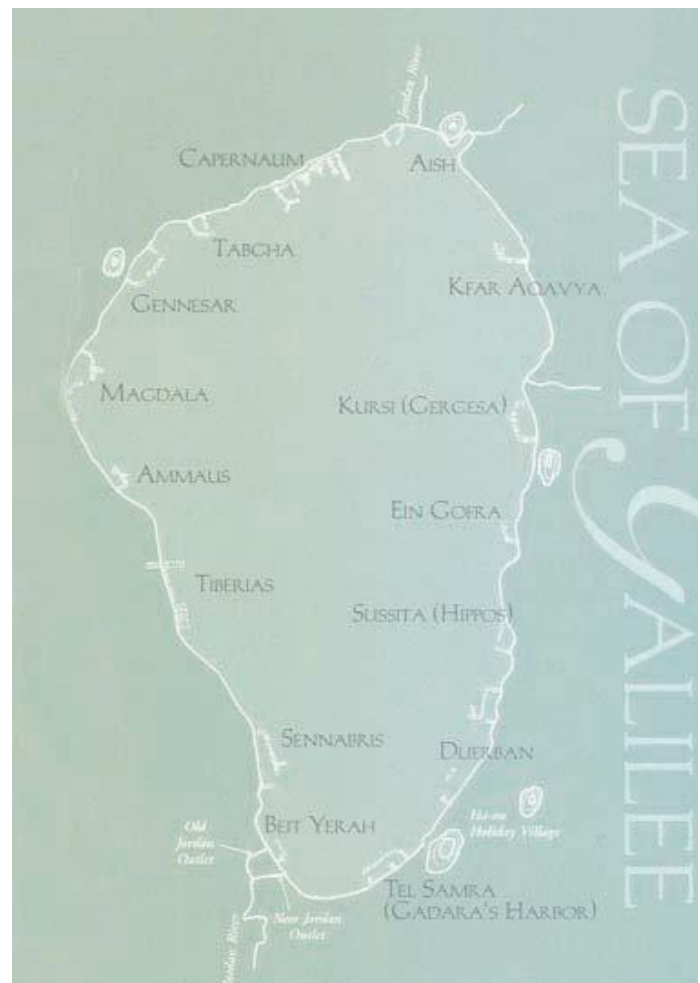

*At least 15 man-made harbors dotted the shores of the Sea of Galilee, known in Hebrew as the Kinneret. The harbors consisted of two basic elements (see, for example, Gennesar, on the north-western shore): a short pier jutting straight into the water, and a long curved stone breakwater, which protected moored boats from the violent storms that suddenly sweep across the lake. To enter the harbor, boats slipped through the narrow passage between the pier and breakwater.*

from the sudden, ferocious storms common on the Sea of Galilee, such as the wind-storm of Luke 8:23 that “swept down on the lake,” filling the disciples’ boat with water.

Covered by a thick layer of silt today, the Kursi harbor was once the commercial center of a typical fishing village from the Roman and Byzantine periods. Built of rows of lightly chiseled basalt boulders, the 500-foot breakwater turns slightly away from the shore, enclosing a narrow area of about half an acre (330 feet long by 80 feet wide). To the north is a shallow pool, built 3 feet above the ground and measuring about 10 feet by 11 feet, where fishermen stored large live fish caught with dragnets.<sup>b</sup> The pool’s plastered interior allowed it to retain water, which came not from the lake but through a small aqueduct leading from a nearby stream. The pool stood directly on the market pier, where fishermen sold their daily catch. Today only the rectangular oundation of this 25- by 16-foot pier can be seen during the dry season. North of the pool are the foundations of a public building—apparently associated with harbor administration—with the remains of a mosaic floor. Nearby I discovered more than a hundred lead net sinkers.

Janet Frankovici/Jerusalem Perspective

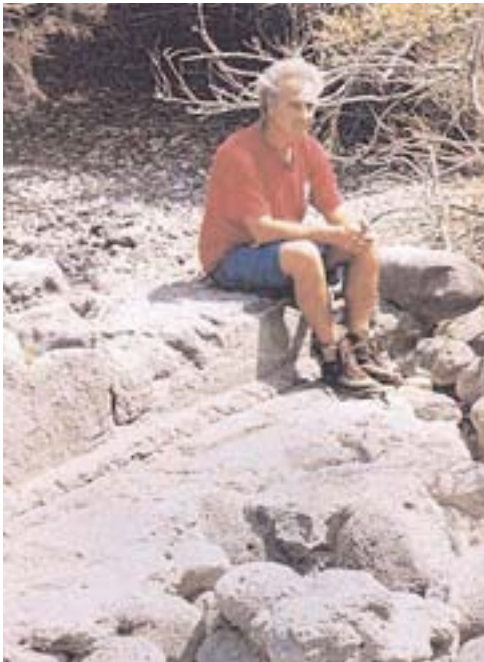

*The daily catch at Kursi was kept fresh in a shallow 10- by 11-foot holding tank. In the photo, an unidentified man is sitting on the edge of the plastered pool, which was filled with water from a nearby stream.*

Waves have eroded the shore further to the north, exposing one room of yet another building. Here I found sections of columns, marble fragments and bits of colored mosaics that led me to think this was probably Kursi’s synagogue, dating from about 400 to 700 C.E.

At Kursi, I also found traces of a Roman road branching off the main road (which ran from the south to the Golan Heights) and leading down to the harbor. Ruins of houses surrounded the shore.

Ironically, the harbor at Kursi is generally visible most months of the year—more often than any other harbor on the lake. It could easily have been discovered without underwater efforts. Earlier explorers must have seen these ruins often without recognizing them as the remains of a fishing village and its harbor.

During the winter, however, the fish pool, synagogue and administration building of Kursi are underwater, indicating that the lake was lower during the first millennium C.E.

Most of the ancient harbors of the Sea of Galilee were not identified until more recently because they are underwater for much of the year. The foundations of the breakwaters were built when the water level was at its lowest (about 695 feet below sea level). Although the breakwaters were originally about 10 feet tall, over the years the

Mendel Nun



Steep cliffs led from the village of Kursi down to the harbor, where the larger boulders that once made up the 10-foot-tall breakwater are still visible. In the 1970s, a bulldozer unearthed a Byzantine church built on the hill to accommodate pilgrims to Kursi (called Gergesa, Gadara or Gerasa in the New Testament and other ancient manuscripts), the traditional location of Jesus' swine miracle. According to the Gospel of Luke 8:33, when Jesus freed a tormented man afflicted with demons, "the demons came out of the man and entered the swine, and the herd rushed down the steep bank and into the lake and was drowned."

waves have demolished them, leaving behind only the foundations, visible when the water level is lowest, after a dry summer. Further, as we shall see, the maximum level of the lake in the Roman period was about 4 feet lower than it is today, and the shallow shoreline was up to 150 feet further out. Consequently, the foundations of the promenade are further from shore than they were in ancient times.

A natural change in the outflow of the lake about 1,000 years ago led to this rise in the water level. The old outlet of the Jordan River was originally located near today's village of Kinneret. Over the centuries, however, the pounding waves created a weak point in the soft alluvial shoreline to the south of the old outlet, near Kibbutz Degania. Eventually, this developed into a second, deeper but narrower outlet for the Jordan River. This second outlet must have existed by 1106, when it is mentioned in the writings of a Russian pilgrim to the Holy Land. From later literary sources, we know that the Jordan River continued to have two outlets on the southern Galilee shore for hundreds of years thereafter. The newer outlet had a smaller capacity, however, and over the centuries, as silt blocked the older outlet, the maximum level of the lake gradually rose about 3 feet.<sup>c</sup>

With the discovery of Kursi in 1970, I became attuned to what an ancient harbor looked like. Touring the shore on my near-ancient bicycle, I began to search for more. I soon discovered the harbor of Capernaum—much to the surprise of the Franciscan monks at the monastery of Capernaum, who were in the habit of dumping rubble from their own excavations into the harbor.



Janet Frankovici/Jerusalem Perspective

Author Mendel Nun (his adopted surname means "fish" in Aramaic) balances on the harbor pier at Kursi.



*A bustling port welcomed visitors to the prosperous village of Capernaum in Jesus' time. A 2,500-foot-long promenade lined the shore. Boats moored along the harbor's array of paired curved piers, straight docks and triangular piers. The remains of these unusually shaped piers are still visible during dry seasons.*

According to the Gospels, Capernaum was the center of Jesus' Galilean ministry.<sup>d</sup> Here Jesus preached at the local synagogue (Mark 1:21) and healed the paralytic (Mark 2:3–12). The Gospel of Matthew indicates that Jesus stayed at Peter's house, where "he cured many who were sick with various diseases, and cast out many demons" (Mark 1:32). The Franciscans have been excavating at Capernaum for a century. Nearly 50 years ago, they began work on the building known as St. Peter's house. One spring, the Fran-

ciscan archaeologists were forced to stop their work because the sea, having reached its maximum seasonal level, flooded the area around St. Peter's house—further proof that the sea is higher today than in ancient times.

Occupied for more than a thousand years, from the second century B.C.E. until the tenth century C.E., Capernaum at its height extended about half a mile along the shore. Although I knew the city must have had a harbor, the unusually rocky topography made it difficult to locate. Instead of looking for rocks, as I usually did, here I searched for (and found) a clearing where rocks had been removed to make a safe port.

Along the shore ran a 2,500-foot-long promenade, or paved avenue, supported by an 8-foot-wide seawall. The portion of the promenade on the Franciscan property had been covered by rubble and was partially destroyed by modern building. But impressive sections to the north, on land owned by the adjacent Greek Orthodox church, and further to the east, were hardly damaged.

To protect the shore from storms, a promenade must be at least 2 feet above the maximum sea level. A modern promenade at Tiberias, built in 1932 on the western shore, is about 2 feet higher (684 feet below sea level) than the sea's maximum level (686 feet below sea level). The ancient Capernaum promenade is about 3 feet lower (687 feet below sea level). This provides solid evidence that the sea was about 3 feet lower in ancient times. Further proof of this is seen in the drainage channel (at about 687 feet below sea level) of the Roman baths at Capernaum. If the baths were in operation today, they would be flooded whenever the lake reached its maximum level.

Vessels at Capernaum could load and unload cargo and passengers on several piers that extended about 100 feet from the promenade into the lake. Some of the piers are

Leen Ritmeyer



*In this representation of biblical Capernaum as drawn by archaeological draftsman Leen Ritmeyer, Capernaum's synagogue, where Jesus preached (John 6:59), appears at upper left. It is shown with three doors and a raised central roof with an arched motif at one end. The building identified since the fourth century as the home of the apostle Peter lies between the synagogue and the harbor. According to Matthew 8:14–16 and Mark 2:1, Jesus lodged here. The home consists of several small rooms built around two central courtyards.*

paired and curve toward each other, forming protected pools. Others are triangular in shape. According to the New Testament, under the rule of Herod Antipas a marine toll station was located at Capernaum, with the apostle Matthew in charge (Matthew 10:3). The port apparently served not only the local population but also travelers who preferred the swift, comfortable transportation available on the lake.

In the winter, fishermen from Capernaum worked at Tabgha, where several warm mineral springs attracted musht, popularly called St. Peter's Fish. (The name Tabgha is a corruption of the Greek for "Seven Springs.") Today the remains of this small harbor's breakwater can be seen when the

water level is low. Christian tradition ascribes the meeting place of Jesus with his disciples to a prominent rock at the warm springs. From a fisherman's viewpoint, this is the correct choice. This is the area where musht schools formerly concentrated in the winter and spring. Here Jesus met his disciples for the first—and also the last—time (Luke

Garò Nalbandian



*The ancient harbor of Capernaum extended from the area now owned by the Franciscan church, at left in the aerial photo, to the Greek Orthodox church at right.*



5:1–7; John 21:1–8). On this rock, now known as the rock of the primacy of Peter, stands a small modern Franciscan chapel, the Church of the Primacy of Peter. It was built on the foundations of earlier churches, the oldest of which dates from the first half of the fourth century. The altar is built around a stone outcropping known to pilgrims as the Lord’s Table (*Mensa Domini*), on which Jesus served the disciples after the miraculous draught of fishes (John 21:13).<sup>e</sup>

The various names by which Magdala was known bear witness to this town’s maritime character: Migdal Nunieh (in Hebrew, Fish Tower) and Tarichea (in Greek, The Place Where Fish Are Salted). According to Josephus, Magdala had many boats, shipyard workers and supplies of wood. In the Great Jewish Revolt against Rome (66–70 C.E.), Magdala served as the base of the Zealots, one of the Jewish factions involved in the revolt.

Garo Nalbandian

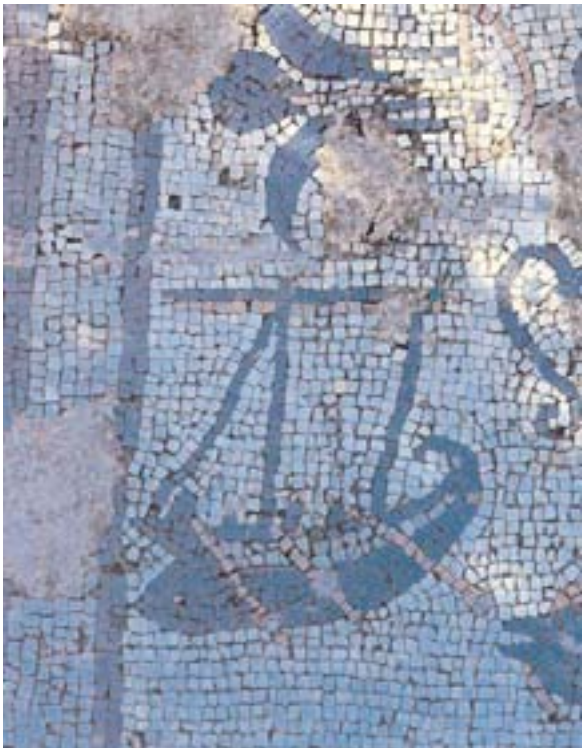

Decorating a first-century C.E. home in the seaside town, a mosaic depicts a boat with a mast for sailing and oars for rowing.

The remains of the Magdala harbor were discovered near an excavation site where Franciscan monks had already uncovered the central square, streets and buildings of the first-century C.E. town that Mary Magdalene called home. In one house, they found a mosaic of a sailing boat. As at Capernaum, the earlier excavators failed to detect the ancient harbor, which they used as a dump.

The port of Magdala was constructed in two parts—a promenade and a sheltered basin. The promenade, which runs parallel to the shore, starts below the ruins of the Arab village of Migdal and continues to the north for about 300 feet. In the early 1970s, the outlines were clear and complete, but rapid silting and development have since altered the topography.

Not far from Magdala, a two thousand-year-old boat similar to ones Jesus must have used was found perfectly preserved by the mud.<sup>f</sup>

The first communities to build “modern” harbors on the Sea of Galilee were the Hellenistic cities of Hippos (in Aramaic, Sussita) and Gadara, located east of the Sea of Galilee. Founded in the third century B.C.E., Sussita was a natural fortress, located securely on a 1,000-foot hill overlooking the sea.<sup>g</sup> A reference in the *midrashim*<sup>h</sup> led me to believe that Sussita had a suburb, or lower city, on the shore and a harbor. As the midrash (*Bereshit Raba* 32.9) puts it, Noah’s Ark, though very heavy, nevertheless sailed as easily “as from Tiberias to Sussita.” Agricultural produce was shipped from Sussita to Tiberias, the mid-first-century C.E. capital of Galilee,



*“The place where fish were salted”—a rough translation of Tarichea, Magdala’s Greek name—suggests that the Galilee’s fish-processing industry was centered at this harbor. The more familiar Aramaic name of the town is preserved in the moniker of the most famous resident, Mary Magdalene, the first witness to Jesus’ Resurrection.*

on the western shore. For those traveling from the west, the harbor served as the gateway to the Golan.

For more than 50 years, I have lived near ancient Sussita, at Kibbutz Ein Gev. But until the harbor of Kursi was discovered in 1970, I did not recognize the stone walls

south of Ein Gev as the remains of the ancient harbor. A few years later, while preparing the ground for a date plantation south of the kibbutz, we uncovered the remains of the entire maritime suburb of Sussita, covering 15 acres near the harbor. I also found a section of the Roman road connecting the upper and lower cities. Based on ceramics found here, we know the settlement lasted from the Hellenistic to the Arab period (about the third century B.C.E. to the eighth century C.E.).

The harbor’s main breakwater was about 400 feet long and up to 20 feet wide at its base. This breakwater extended along the northern side of the harbor and then turned south, running parallel to the shore. A second, shorter breakwater extended from the shore to protect the southern side of the harbor. The harbor thus created is about an acre in size. A small pier extended into the sea from the breakwater, allowing passengers to embark and disembark without entering the crowded harbor. Today silt fills the harbor.

Gadara, the most magnificent of the Hellenistic towns that circled the Sea of Galilee, was located on the heights of Gilead above the Yarmuk River. The marine suburb and

*About a mile north of Migdal, a perfectly preserved wooden boat—also equipped for rowing and sailing—was found in the mud. Apparently, a master craftsman from the time of Jesus built the boat to last.*



the city's harbor were located on the southeastern shore of the lake, at Tel Samra (now Ha-on Holiday Village). In form, Gadara's harbor resembles that of Sussita—a closed basin with an opening to the south—but it is much larger and more luxurious. The central breakwater is 800 feet long and its base 15 feet wide. The promenade was 650 feet long, built with finely chiseled stones, only one of which remains. The 150-foot-wide basin covered an area of 3 acres.

This harbor is superior to the one at Sussita not only because of its size but also because of its facilities. At the center of the promenade are the remains of a tower. Ruins of a large structure—probably the building of the harbor administration—are scattered on the ground near the harbor gate.

Gadara's maritime character is attested by its coins, which depicted ships of war for some 250 years. The city's harbor at Tel Samra was almost certainly not only an anchorage for ships. Second-century coins from Gadara commemorate the *Naumachia*—naval battle games performed for the inhabitants of Gadara. Until recently, researchers assumed that these games took place on the Yarmuk River, which flows into the Jordan just south of the Sea of Galilee; but this does not seem likely, and no remains of a facility of this kind have been found at this site. The large harbor basin at Tel Samra, however, with its 1,600-foot-long combined promenade and breakwater, would surely have been more suitable to



Mendel Nun

*Perched on a lonely promontory a thousand feet above the sea, Sussita was one of the first Galilee cities to construct a harbor (below the town). In the first century B.C.E., Sussita gained jurisdiction over the neighboring region when it became a member of the Decapolis, the League of Ten Cities created by the Roman general Pompey in the Jordan Valley and in Transjordan. Ships from Sussita apparently ferried grain and other commodities to many locales around the sea: The Talmud describes Sussita and the surrounding region as the breadbasket of Tiberias, the largest city on the western shore of the Galilee.*



Garo Naibandian

*The ruins of a Byzantine church lie on the bluff where the city once stood. The marble and granite columns from the church's nave fell like dominoes during an earthquake in 749 C.E. Shaped like a horse's head, the cliff on which the city stood, some scholars claim, gave Sussita its name, which means "mare" in Aramaic; in Greek the city was known as Hippos, meaning "horse."*

Zev Radovan



During the second century, residents of Tiberias celebrated their maritime heritage by minting coins depicting Roman galleys and anchors.

accommodate the throngs of spectators as they arrived. In addition, Gadara's harbor must have been used by thousands of visitors to the famous baths at Hamat Gader, located 5 miles southeast of the sea. The ancient Roman road connecting Beth Shean and Sussita passed near Tel Samra, and the road to Hamat Gader branched off this road.

A drought from 1989 to 1991 helped me discover even more of the ancient shoreline, including the full extent of the harbor of Tiberias, the most important city on the lake today.<sup>1</sup> The significance of the ancient city is reflected in the New Testament reference to the Sea of Galilee as the Sea of Tiberias (John 6:1, 21:1). John also refers to some boats from Tiberias (John 6:23). Coins minted at Tiberias feature anchors, vessels and other naval symbols, as well as the Greek deity Poseidon, who rules the seas and is the patron of sailors and fishermen.

Albatross/Duby Tal



Today only about 500 feet of what was once the Tiberias shoreline remain undisturbed. This area lies south of the fifth-century C.E. Byzantine defense wall.

Thought-provoking ruins have long been noted along this sector. They include impressive segments of a promenade running parallel to the modern road, with an opening leading to the shore. Further south along the shore, the ruins of six rows of columns extend for about 80 feet, with remnants of several of the basalt, limestone and marble columns toppled on the ground and others

Galilee's most important harbor—from ancient times to today—lends its name to the sea in the Gospel of John, which describes Jesus' post-Resurrection appearance beside "the Sea of Tiberias" (John 21:1).

The modern city is one of Israel's most popular vacation spots. In the Arabic period, too, Tiberias proved to be a favorite watering hole. Massive columns once rose above the water to support an Arabic pleasure palace. The column drums lie in rows along an 80-foot stretch of shore.

But although these ruins have long been visible, until recently author Mendel Nun did not think they marked the location of Tiberias's ancient harbor. During a drought in 1989 to 1991, however, Nun discovered hundreds of anchors, mooring stones and net sinkers on the shore, indicating that the harbor, usually completely underwater, was located here, south of the modern city (far right in this aerial photo).

re-erected upside down. This structure was probably built during the Arab period (eighth and ninth centuries C.E.), reusing earlier materials. The Persian traveler Nasir Husro, who visited Tiberias in 1047 C.E., described the “pleasure houses” supported by “columns of marble rising up out of the water.” This evidence points to an elegant Tiberias promenade that once stood where today a road leads from the modern city to nearby hot springs.

I always doubted that this was part of the ancient harbor. But I was wrong. During the drought of 1989 to 1991, I spent countless hours scouring the newly exposed shoreline at Tiberias. As I searched, I began to find stone anchors, mooring stones and hundreds of stone net sinkers. I knew that the stones, which weighed between 20 ounces and 5 pounds, were connected with the fishing industry because of their form and because of the holes drilled in them (note the stone anchors lying on the piers in the reconstruction drawing). In all my years of searching, I had never found so many stones like this at one site. Although there is no fishing area adjacent to the find-spot, I knew I had found the strongest possible evidence that many fishermen had moored here for centuries, preparing their nets and equipment before going out to sea. All that was missing to complete the picture of the Tiberias harbor was the breakwater.

Mendel Nun



*During the Byzantine period, the city wall of Tiberias was extended into the water (the foundations are visible in the photo), so that the city remained well protected on all sides, even when the water was low.*



Israel Antiquities Authority

*In the Arabic period, Tiberias proved to be a favorite watering hole. Massive columns—visible in this photo from the 1920s—once rose above the water to support an Arabic pleasure palace. The column drums lie in rows along an 80-foot stretch of shore.*

Finally, after years of searching, I found a few clues, remains of a breakwater that had run parallel to the promenade. But until an archaeological dig is made at this site, it will not be possible to draw a complete plan of the harbor.

When I began my investigations, I never dreamed that I would be blessed with

the chance to work during a special period of unusual phenomena. The drought of 1989 to 1991 provided a unique opportunity to reveal more of the splendid history of this famous lake.

We discovered that all settlements on the shore of the Sea of Galilee, even the smallest, had harbors, each built to suit local conditions and requirements. (The above descriptions are only a part of our findings.) These harbors continued to flourish throughout the Byzantine period (324–638 C.E.). With the gradual economic decline that followed the Arab conquest in the seventh century, the harbors were neglected. Pounding waves destroyed the breakwaters, and valuable stone blocks were removed and reused elsewhere. Today's scant remains bear witness to a high, at times magnificent, quality of building, especially on the promenades. These surviving stones provide us with a tangible connection to the thriving towns and ports of Jesus' time, and to the villagers and fishermen who once walked and sailed here.

## Notes

- a. See Vassilios Tzaferis, "A Pilgrimage to the Site of the Swine Miracle," **BAR** 15:02.
- b. See Mendel Nun, "Cast Your Net Upon the Waters—Fish and Fishermen in Jesus' Time," **BAR** 19:06.
- c. The old outlet can still be traced. Remnants of the Roman bridge that crossed this outlet have survived.
- d. See James F. Strange and Hershel Shanks, "Has the House Where Jesus Stayed in Capernaum Been Found?" **BAR** 08:06.
- e. See Dodo Joseph Shenhav, "Loaves and Fishes Mosaic Near Sea of Galilee Restored," **BAR** 10:03.
- f. See Shelley Wachsmann, "The Galilee Boat—2,000-Year-Old Hull Recovered Intact," **BAR** 14:05.
- g. Vassilios Tzaferis, "Sussita Awaits the Spade," **BAR** 16:05.
- h. Midrash (plural, midrashim) designates a genre of rabbinic literature that includes homilies and commentaries on specific books of the Bible. It dates roughly from the second to the fourteenth century C.E.
- i. See Yizhar Hirschfeld, "Tiberias—Preview of Coming Attractions," **BAR** 17:02.

## Why Jesus Went Back to Galilee

By Jerome Murphy-O'Connor

---

Bridgeman/Art Resource, NY



*“Christ preaching on the Sea of Galilee,” by Jan Bruegel the Elder (1568–1625). “Such a very large crowd gathered” around Jesus when he began teaching parables beside the sea that he preached from a boat while his audience remained on the shore (Matthew 13:1–2//Mark 4:1–2). As many of the Galileans flock around Jesus’ boat (center) in Bruegel’s painting, others continue to haul fish from their boats (lower right) and clean their catch (lower left). Jesus could presumably have attracted far greater crowds, and had more influence, in Jerusalem, the religious and political center of Jewish life.*

*Jesus must have had a compelling reason to center his ministry in this rural area. His motive may be gleaned from at least one passage in the Gospels: “When [Jesus] heard that John [the Baptist] had been arrested, he withdrew into Galilee” (Matthew 4:12//Mark 1:14). Did Jesus feel obliged to take over the ministry abruptly terminated by the Baptist’s arrest?*

**W**hy did Jesus go back to preach in Galilee? The question may seem a silly one. After all, he was a native of Nazareth in Galilee, and it was natural that he should preach to his own people. The prophet Amos, however, came from Tekoa (Amos 1:1), a village that differed little from Nazareth, but he did not waste his breath on his neighbors in the rural south of Judah. His mission was to the kingdom of Israel, and he went straight to “the very center of the house of Israel” (Amos 7:10), to the sanctuary of the king and the national temple at Bethel (Amos 7:13). The prophet Elijah was apparently from Gilead, east of the Jordan (1 Kings 17:1), but as the champion of Yahweh he crossed the Jordan Valley to confront King Ahab in Samaria (1 Kings 18 and 21).

To succeed, a reform movement has to find and grip the levers of power. No prophets appeared in what used to be the northern kingdom after the destruction of Israel by the Assyrians in 722 B.C. Thereafter, prophetic voices sounded only in the south, where the central institutions of the Jewish people were located. The parallels suggest that, since Jesus had a mission to the Jewish people, it would have been much more efficient to have concentrated his energies in Jerusalem. Not only were there more people to hear him, but at the pilgrimage feasts his audience would have included visitors from all over the country, as well as from the Diaspora. Moreover, a change of attitude among Jerusalemites might have influenced Jews in Galilee, but certainly not the other way around. Clearly, a ministry of Jesus in Galilee calls for explanation.

I shall argue here that Jesus went to Galilee to replace John the Baptist after the latter had been arrested by Herod Antipas.<sup>1</sup> As we shall see, the Baptist had been preaching in Galilee. His arrest put a stop to this. Jesus felt it was his responsibility to take over where the Baptist had been forced to leave off.

Those who think they know the gospel narrative commonly imagine the following succession of events: Jesus made a journey from Galilee down the Jordan Valley to the northern end of the Dead Sea, where he was baptized in the Jordan River by John. Jesus then underwent 40 days of testing by the devil in the desert, after which he returned to Galilee.

This, however, is not what the gospel says. A closer look at the text reveals that he must have spent substantial time in the south. Jesus' return to the Galilee is dated, not by his 40-day experience in the desert, but by the Baptist's arrest. According to Mark, "After John [the Baptist] was arrested Jesus came into Galilee preaching the gospel of God" (Mark 1:14). Similarly Matthew, "When he heard that John had been arrested, Jesus withdrew into Galilee" (Matthew 4:12).<sup>2</sup>

Let us look more closely at the relationship between Jesus and John the Baptist. We begin with Jesus' baptism—by John. Jesus' baptism is described in all three Synoptic Gospels—Matthew, Luke and Mark.<sup>a</sup> The parallel passages are set forth in the first sidebar to this article. An examination of these parallel passages reveals a curious fact: Mark is the only one to say flatly that John the Baptist baptized Jesus!

Although Matthew says that Jesus came to the Jordan to be baptized by John (Matthew 3:13), the actual baptism is expressed in the passive voice, "when Jesus was baptized" (Matthew 3:16). In light of the preceding verses, the baptism can only have been administered by John, but it is a little disconcerting that it is not said explicitly.

Luke also uses the passive voice: "Jesus also had been baptized" (Luke 3:21). Moreover, in Luke there is no implication that John baptized Jesus; on the contrary, this possibility is specifically excluded because in Luke's account the Baptist has already been imprisoned by Herod Antipas (Luke 3:19–20), and he will never leave his prison alive. (In Matthew and Mark, John's imprisonment comes much later [Matthew 14:3–4; Mark 6:17].)



Luke must have known that John baptized Jesus. There is no hint in any source that the baptism was administered by anyone else. Luke, therefore, is not telling a straight story. He is manipulating history to convey a theological message. John the Baptist was, for Luke, the last of the prophets. John must be moved off the stage of history before the first public appearance of Jesus. This interpretation is confirmed by what we find at the end of Luke's gospel and at the beginning of the Acts of the Apostles.<sup>b</sup> Luke is the only evangelist to mention the Ascension of Jesus into heaven (Luke 24:51; Acts 1:9). Jesus must be moved off the stage of history before the descent of the Spirit at Pentecost (Acts 2:1–4). By these devices Luke divides the history of salvation into three periods: (1) The Time of the Prophets; (2) The Time of Jesus; (3) The Time of the Holy Spirit.

But Luke has another reason for getting the Baptist off the stage before Jesus' baptism: Luke does not want the Baptist, who had his own following, competing with Jesus. We can appreciate this more clearly by looking at the account in Matthew. Matthew has John confess the superiority of Jesus: John says to Jesus, "I need to be baptized by you," rather than the other way around (Matthew 3:14). Jesus declines this request (Matthew 3:15).

Both Mark and Luke lack these verses. Were they added by Matthew or were they omitted from Mark and Luke? Since no good reason can be postulated for their omission, they must be considered an insertion by Matthew. Why did Matthew make this addition? He must have had a serious reason. The most obvious hypothesis is that some people in the early Church insisted that Jesus was inferior to John the Baptist. After all, it was Jesus who came to John, not the other way round. In the culture of the Near East, no one condescends to visit a social inferior. Moreover, Jesus accepted baptism for the remission of sins at the hands of John, whereas nothing is ever said about John's undergoing a similar rite of repentance. Matthew's insertion must be a reaction against the exaltation of John at the expense of Jesus.

This situation helps us to understand why Luke omits entirely an account of *John's* baptizing Jesus, indeed, even excludes the possibility by having John imprisoned prior to Jesus' baptism. Luke must have been aware of a current of thought that exaggerated the importance of John. Both evangelists, Luke and Matthew, in their own way, attempt to distance Jesus from John.<sup>3</sup>

On the other hand, if Jesus' baptism by John proved to be such an embarrassment to the early Church, the story certainly would not have been created by Christian theologians. They had to deal with a fact that they could not deny. The historicity of the event, therefore, is beyond dispute. The details are given by Mark with exemplary thoroughness and brevity: "In those days Jesus came from Nazareth of Galilee and was baptized by John in the Jordan" (Mark 1:9).

As Jesus is being baptized, he has a vision of the Holy Spirit descending from the opened heavens and hears a heavenly voice. Did these things really happen? Or are they a theological interpretation of Jesus' baptism? The second alternative is the more

probable, because Jewish theologians were using the same technique at this time to interpret events in their scriptures. To appreciate this fact, simply contrast the text of Genesis 22:10 with the midrashic expansion in the Targum, an Aramaic paraphrase/translation of the biblical text used in synagogues at the turn of the era. In the Hebrew text, Abraham raises the knife to sacrifice his son Isaac, in accordance with God's direction, when an angel of the Lord calls to him from heaven and tells him to desist. In the Aramaic Targum (the text known as Pseudo-Jonathan), the heavens apparently open at this point for, we are told, "the eyes of Isaac were scanning the angels on high" and "a voice came forth from the heavens." In the Targum, the original text of Genesis 22:10 is expanded to include an interpretation of the sacrifice of Isaac as involving a vision and a voice.

How would first-century Jews, hearing this version in the synagogue, have understood it? Would they have taken the vision and the voice as a description of something that really happened? I think not. They knew the Hebrew text of their scriptures, which contain nothing like that. Similarly, when Christian theologians wanted to bring out the meaning of the baptism of Jesus, of which everyone had heard, they naturally turned to a familiar interpretive technique, whose implications would have been understood immediately by their first-century hearers/readers. The people hearing and reading these accounts would not have taken the vision and the voice literally. Their training in the synagogue would have led them to ask what the symbols were meant to convey. In all probability, the cluster of highly charged terms



Scala/Art Resource, NY

*Salome's dance (top) at the birthday feast of her step-father, Herod Antipas, seated at the center of the banquet table, so pleases the ruler of Galilee and Perea that he promises to give her whatever she wishes. Prompted by her mother, Herodias, in white at left, Salome requests "the head of John the Baptist on a platter" (Matthew 14:8). In this late-15th-century fresco by Domenico Ghirlandaio for Santa Maria Novella, in Florence, a servant presents the head to Antipas, who had arrested John in Galilee for his condemnation of Antipas's marriage to his brother's wife, Herodias. (Although the Bible does not name Salome, the first-century Jewish historian Flavius Josephus recorded her identity.)*

*In the bottom register, John baptizes Jesus (left) and preaches in the wilderness (right). By wearing a hairy cloak (Matthew 3:4//Mark 1:6) like the prophet Elijah's (2 Kings 1:8) and by preaching in the desolate region of Perea, east of the Jordan, where Elijah was taken up to heaven in a chariot of fire, John likened himself to the Old Testament prophet, announcing the coming of the day of judgment.*

in the evangelists' descriptions were designed to evoke the great prayer of Isaiah 63:7 through 64:11. Note the correspondences between the italicized words in the following quotation from Isaiah and the descriptions of Jesus' vision in the first sidebar to this article, especially in Mark's version of Jesus' vision when John baptized him:

Then they remembered the days of old and Moses, his servant. Where is he who brought up out of the sea the shepherd of his flock? Where is he who put his holy spirit in their midst...A spirit from the Lord descended guiding them...Look down from heaven and regard us from your holy and glorious palace! O Lord, hold not back, for you are our father. Were Abraham not to know us, nor Israel to acknowledge us, you, Lord are our father, our redeemer you are named forever...Oh, that you would rend the heavens and come down, with the mountains quaking before you...All that was dear to us was laid waste. Can you hold back, O Lord, after all this? Can you remain silent, and afflict us so severely?

(Isaiah 63:11, 14, 15–16, 19; 64:10–11)

The number of the correspondences excludes coincidence. Christian theologians intended in the Gospels to present the beginning of the public life of Jesus as the response of God to the petition of his people. His people are no longer alone because God is no longer silent. God has spoken about Jesus, and God acts in and through Jesus. This interpretation, however, presupposes the whole ministry of Jesus culminating in his death and resurrection. The interpretation grew out of the experience of divine grace in the early Church, which was the medium by which the first believers gradually came to know who Jesus really was. Our concern here, however, is with the historical question. What did Jesus' baptism mean to Jesus?

Since Jesus himself nowhere explains his motives, we can only speculate. At one end of the scale are those who argue that Jesus was simply making a public gesture of support for John's role and message.<sup>4</sup> At the other end of the scale are those who think that Jesus needed forgiveness. Thus, for example, Paul W. Hollenbach tells us, "We may suspect that through John's preaching Jesus discovered that he had participated directly or indirectly in the oppression of the weak members of his society."<sup>5</sup>

The possible permutations and combinations are virtually infinite. And in the end no certitude is possible. To spend further time on the issue would be futile. What can be said with certitude, however, is that John the Baptist was explicitly recognized by Jesus as a figure of key importance in his own religious development. Given what we have seen of the resistance of the Church of the late first century to admitting the dependence of Jesus on John, it is most improbable that believers would have invented the praise that Jesus lavishes on John. The evangelists had to record Jesus' baptism by John, Jesus' praise of John and Jesus' recognition of John's importance because all this was part of the tradition—but, where possible, the evangelists attempted to neutralize it.

For example, both Matthew and Luke quote Jesus as saying, "Among those born of women there has risen no one greater than John the Baptist" (Matthew 11:11a//Luke 7:28a), but an editor added immediately thereafter, "Yet he who is least in the kingdom

of heaven is greater than he” (Matthew 11:11b//Luke 7:28b). Similarly, Jesus says that John “was a burning and shining lamp, and you were willing to rejoice for a while in his light,” but in its present context this compliment is immediately followed by, “But the testimony which I have is greater than that of John” (John 5:35–36). Elsewhere, the ministry of John is presented in unmistakably positive terms, which it would have been difficult to attenuate: “John came to you in the way of righteousness, and you did not believe him, but the tax collectors and the harlots believed him; and, even when you saw it, you did not afterward repent and believe him” (Matthew 21:32). Finally, Jesus sets in parallel criticisms of himself and of John: “John came neither eating nor drinking, and they say, ‘He had a demon.’ The son of Man came eating and drinking, and they say, ‘Behold a glutton and a drunkard’” (Matthew 11:18–19//Luke 7:33–34).

The cumulative effect of these passages has been well summed up by James M. Robinson: “To this extent Jesus did look back on [John the Baptist] as the Church later looked back on Jesus...There is as a matter of fact in Jesus’ clear confession to John something analogous to the Church’s kerygma.”<sup>6</sup> In other words, what Jesus was to the Church, so in some sense John was to Jesus. The Church is incomprehensible without Jesus. Equally, Jesus is incomprehensible without John the Baptist. Jesus felt that he owed something fundamental to John.

The next question we must ask is this: If Jesus owed something fundamental to John, could that debt have been incurred in the few moments of John’s baptism of Jesus? This seems highly improbable. Jesus must have spent considerable time with John.

But when and where? The answer may come from the Fourth Gospel, the Gospel of John (don’t confuse this John with John the Baptist). By a careful reading of the Fourth Gospel, we can uncover a longstanding relationship between Jesus and John. Indeed, Jesus apparently started out as a disciple of John, working with him in his ministry. The Fourth Gospel consistently places the opening phase of John the Baptist’s ministry beyond the Jordan (*peran tou Iordanou* [John 1:28, 3:26, 10:40]). This had become a technical term for the east bank of the Jordan, which in consequence was known as *Peraia*, “Perea.” This area was a wilderness (Mark 1:4). An analysis of first-century occupation patterns in the area reveals that all the towns and villages in Perea were located around springs above the foothills on the east side of the Jordan Valley.<sup>7</sup> The valley floor, according to the first-century Jewish historian Josephus, was “desert and rough.”<sup>8</sup> It was an area where almost nobody lived and only the hardiest of wild plants survived.

Passing travellers, and in particular Jews on pilgrimage to Jerusalem, would have been the Baptist’s sole audience in Perea.<sup>9</sup> In winter, their numbers were supplemented by the curious among the nobles of Jerusalem and their households when they went down to the warmth of the Jordan Valley to escape the cold of Jerusalem. From Jericho it would have been a pleasant stroll to hear the prophet of the hour.

Nevertheless, John’s choice of location for the beginning of his ministry is a very curious one. The Baptist believed that he had a mission to convert all Israel. Why did he waste his breath in Perea, where there was hardly any permanent population?

The answer is suggested by the fact that the area in which he preached was precisely where the prophet Elijah was taken up to heaven in a chariot of fire (2 Kings 2:4–11). John’s hairy cloak and leather loincloth (Mark 1:6//Matthew 3:4) were identical to those worn by Elijah (2 Kings 1:8). We can only conclude that John was making a prophetic gesture—a non-verbal statement—intended to evoke the proximity of the day of eschatological judgment, which the return of Elijah would precede (Malachi 4:5).<sup>10</sup>

Once the statement had made its impact, however, John had to seek out Jews. Time was running out; as he himself said, “Even now the axe is laid to the root of the trees” (Matthew 3:10//Luke 3:9). He could no longer stay in the wilderness in the hope that penitents would come to him.

When the Baptist did decide to move into the populated areas on the west side of the Jordan River, it was in accord with a careful plan, and he did not go alone. According to the account in John 3:22–24, “Jesus and his disciples went into the land of Judea, and there he remained with them and was baptizing. John also was baptizing at Aenon near Salim, because there was much water there; and people came and were baptized. For John had not yet been put into prison.”

Note that by this time Jesus has disciples. Apparently, Jesus had spent sufficient time with the Baptist in Perea that some of John’s disciples transferred their allegiance to Jesus. According to the final version of the Fourth Gospel, this process took only three days (John 1:29–51), but the schematic nature of this presentation is obvious. The literary evolution of the material in John 1:29–51 is complex, but one can detect an early level of the story in which disciples of John seek out Jesus in response to a recommendation of the Baptist.<sup>c</sup> In John 1:35, the Baptist is “standing with two of his disciples,” who, we later learn, are Andrew and Simon Peter. After hearing John call Jesus the Lamb of God,<sup>d</sup> they decide to “follow Jesus” (John 1:37).<sup>e</sup>

The imperfect tense—Jesus “was baptizing” in Judea (John 3:22)—underlines that this was the location of Jesus’ habitual ministry at this stage of his career. In the same verse we read that “there [in Judea] he remained with them [his disciples]” (John 3:22); this is redundant unless it is a reaction to the view reflected in John 4:2—that Jesus’ visit to Judea was brief and that Jesus’ personal involvement in the baptizing ministry was insignificant. This concern for the accuracy of the historical record is also confirmed by the note in John 3, which tells us that at the time Jesus was baptizing in Judea, “John also was baptizing at Aenon near Salim, because there was much water there; and people came and were baptized” (John 3:23). The text of the Fourth Gospel that immediately follows assures the reader that John was able to baptize because “John had not yet been put in prison” (John 3:24). Why is this note added here? Obviously, if John were in prison, he would not have the freedom to go around and baptize. There appears to be no need to say this. The point of this note must be to date the Judean baptizing ministry of Jesus, and to make it clear that this ministry of Jesus was both prior to, and distinct from, the ministry of Jesus in Galilee at a later date.

As noted, while Jesus was in Judea, John was baptizing at Aenon near Salim (John 3:23). Salim lies almost three miles due east of Tel Balata, the site of ancient Shechem, in the center of ancient Samaria.<sup>11</sup> There is no doubt about the location of Salim.

The site of Aenon, which simply means “springs,” is more problematic, although it was probably in the same vicinity as Salim.<sup>12</sup> Within a mile of Tel Balata, on the eastern slope of Mount Gerizim are five springs at an altitude of between 555 and 655 yards.<sup>13</sup> Each undoubtedly had its own name, as they have today, but as a group they were probably identified by reference to Salim, which was then the nearest inhabited site. (Shechem, a much more important city, was closer, but it was never reoccupied after having been sacked by John Hyrcanus in 107 B.C.<sup>14</sup>)

In short, while Jesus was baptizing in Judea, John was baptizing in Samaria. The obvious implication is that the baptizing ministries of John and Jesus were a coordinated campaign among Judeans and Samaritans. John as the leader took the more difficult task; he worked in Samaria. The state of relations between Jews and Samaritans is graphically illustrated in a parable in which Jesus tries to force Jews to admit that a Samaritan could be good (Luke 10:23–37). The hatred was such that Samaritans refused hospitality to Jewish pilgrims from Galilee en route to Jerusalem (Luke 9:52–56). In Samaria, John had two strikes against him. Not only was he a Jew, but he came from priestly stock (Luke 1:8–13) and was thus associated with the Temple in Jerusalem, which represented the antithesis of everything the Samaritans stood for. Until it was destroyed, the Samaritans had their own temple on Mt. Gerizim. In their version of the Pentateuch, Mt. Gerizim, not Jerusalem, was the holy mountain. Not surprisingly, therefore, John was less successful than Jesus (John 3:26, 4:1). Jesus had an advantage, because he worked ground that had been prepared by those who had come to hear John at Perea (Mark 1:5).

Eventually John decided to call it a day and to seek greener pastures. He had little choice about where to go. He had already preached in Perea. Jesus was doing well in Judea. Of the three Jewish provinces, only Galilee remained.<sup>15</sup>

Whether John recognized the danger of going to Galilee is difficult to say. Sometime before 23 A.D.,<sup>16</sup> Herod Antipas, ruler of Galilee and Perea, dismissed his wife in order to marry Herodias, his brother’s wife, who was also his niece (Mark 6:17–18).<sup>17</sup> Jewish law forbade marriage with a brother’s wife (Leviticus 18:16).<sup>18</sup> As early as his preaching in Perea, John may have felt it his duty to attempt to correct Antipas: The ruler of a Jewish state should provide a good example to his people. Antipas could do nothing to stop John as long as John stayed outside Antipas’s territory. John was safe in Judea and Samaria because these areas were under direct Roman control. Only when John went to Galilee did he again become vulnerable.

John saw his criticisms of Antipas’s behavior from a religious perspective; the law of God had been broken. For Antipas, however, John’s criticisms created a political danger.<sup>19</sup> Antipas cannot have been unaware of the severe political damage his brother Archelaus suffered because of his illegal marriage to Glaphrya, who had previously

been married to Archelaus's half-brother Alexander.<sup>20</sup> Antipas had every reason to fear that John's scathing attack on his marriage to Herodias would alienate his Jewish constituency in Galilee just at the moment when he needed to have his country completely on his side.

Josephus describes the situation in detail.<sup>21</sup> The dismissed wife of Antipas was a Nabatean princess, a daughter of Aretas IV of Petra. Her spies among Antipas's retainers had informed her of his intention to divorce her. Before he was aware that she knew of his plans, Antipas gave her permission to visit the great fortress/palace of Macherus in the southern part of Perea overlooking the Dead Sea. With the aid of the troops of Aretas, she slipped across the border into Nabatea and was reunited with her father. The insult to the honor of the Nabatean royal family was intolerable, and it was clear to everyone that Aretas would seek revenge. The only questions were where and when.

To forestall a Nabatean invasion of his territory in Perea, Antipas moved south from Galilee to Macherus. He also had the Baptist arrested for criticizing his marriage to Herodias. He could not allow John to stay loose in Galilee while he himself went to Perea to meet the Nabatean threat; instead, he brought his prisoner with him to

Macherus. At some point, while John was imprisoned in Macherus, Antipas had him beheaded at the request of Herodias's daughter Salome (Matthew 14:6–10; Mark 6:21–28).

The Nabatean ruler Aretas used a border dispute as a pretext for war, which he won decisively. Antipas returned to Galilee to lick his wounds among a population who blamed his defeat on his treatment of the Baptist.

Scala/Art Resource, NY



*The grisly beheading of John the Baptist occurs in a shadowy courtyard outside the fortress-palace of Herod Antipas at Macherus, Perea, in this painting by Caravaggio (1573–1610). When Antipas moved to Perea to forestall an invasion by the neighboring Nabateans, he brought John with him to Macherus as a prisoner. Angered that Herod Antipas had dismissed his royal Nabatean wife so that he could marry Herodias, the Nabateans declared war against Antipas and destroyed his army, writes the first-century historian Flavius Josephus (Antiquities 18.5.1). When the defeated Antipas returned to Galilee, the population blamed his loss to the Nabateans on his murder of the Baptist. "Some of the Jews," Josephus writes, "thought that the destruction of Herod's army came from God, and that very justly, as a punishment of what he did against John."*

How long it took for news of the arrest of the Baptist to reach Jesus in Judea is difficult to estimate. He may have had to wait for a chance word brought by merchants or pilgrims. More likely, one of John's disciples made the four-day journey from Galilee to inform Jesus. In the first century, no one was condemned to prison as a punishment. Those held in confinement were either under investigation (there was no bail) or were awaiting execution. At the beginning, Jesus could not have known which scenario applied to John. There was some hope as long as John was held in Galilee, presumably in its capital city, Tiberias. Jesus would have become seriously worried only when he heard that the Baptist had been transferred to the remote fortress of Macherus in Perea. Although John's death had not yet been decided, it was imperative to maintain the momentum of the Baptist's ministry in Galilee. Jesus decided that it was his responsibility to replace John in Galilee. As the Gospels record, "When [Jesus] heard that John had been arrested, he withdrew into Galilee" (Matthew 4:12//Mark 1:14). Jesus' disciples could carry on in Judea.

According to the Fourth Gospel, Jesus left Judea and went to Galilee because of his fear of the Pharisees, who were dismayed by the success of his baptizing reform ministry (John 4:1-3). To avoid this danger, we are told, he sought security in Galilee. This scenario, however, makes no sense. The Pharisees would have been delighted with anyone who persuaded the people to live up to a higher standard of religious observance. It is much more likely that the Johannine editor was just guessing and, like Luke in other contexts,<sup>22</sup> found Jewish hostility a convenient motivation for a change of location of a character in his story.

Jesus must have been aware that by going to Galilee he was putting himself in danger. Like all rulers in the Middle East, Antipas doubtless had an efficient network of spies and informers. Anyone with a following was an object of suspicion; it might have meant the beginning of an uprising. John was undoubtedly a marked man from the moment crowds gathered to hear him speak in Perea. We must assume that those permanently associated with the Baptist were also noted, and in particular Jesus, who functioned independently in Judea. Since Antipas regularly came into Jerusalem on pilgrimage (Luke 23:7; Josephus *Antiquities* 18:122), he was in a position to have first-hand knowledge of the fact that Jesus's ministry was an extension of the Baptist's. Antipas must have anticipated that Jesus would repeat the Baptist's criticism of his unlawful marriage.

Jesus, in consequence, must have had a very good reason to go to Galilee despite the danger. What was his motive? The little evidence we have unambiguously suggests that he wanted to continue what John had begun, a ministry that had terminated with the Baptist's arrest.

Once in Galilee, Jesus was identified as the Baptist. We learn this from the three parallel passages from the Synoptic Gospels in the second sidebar to this article.

Three points reveal that, of these three passages, Mark's account is the most primitive: (1) In 6:14, Mark does not tell us what Herod heard. For this we depend on



Matthew (“the report about Jesus”) and Luke (“all that was done”). (2) Mark calls Herod “king,” which is incorrect. Matthew and Luke give him his correct title, “tetrarch.” (3) Mark’s tautological and obscure “a prophet like one of the prophets” is simplified and clarified by Luke’s reference to the ancient prophets of Israel. Unless we are willing to assume that Mark set out to be awkward and inaccurate, we must conclude that Matthew and Luke smoothed out and corrected his account. Let us look more closely, then, at Mark’s account, which is the closest to the event. What is striking in this short narrative is the amount of verbal repetition. The fact that Herod “heard” is mentioned twice, as is the “raising” of John from the dead. This normally indicates that something has been inserted into a story. A phrase from the source is repeated after the insertion (in this case the “hearing” of Herod) to facilitate the use of the rest of the material from the source. It provides a smooth continuation.

In this hypothesis, the source would have read, “Herod heard, for Jesus’ name had become known, and said ‘John, whom I beheaded has been raised.’”<sup>23</sup>

If in Mark’s source Jesus was thought to be the resurrected John, it can only have been because Jesus was doing and saying the same things that John had said and done in Galilee. Jesus was proclaiming and performing a baptism for the remission of sins. Jesus’ sense of *noblesse oblige* drove him to minister in the Galilee despite the danger. The mantle of the imprisoned Baptist had fallen on him. He felt that he had no choice but to continue the reforming mission of the Baptist in the place he had been preaching.

While in Galilee Jesus underwent a second conversion; the first had been his acceptance of the call to serve beside John. In Galilee, however, the pattern of his behavior changed. His message was no longer “Repent,” but “Follow me!” The change was radical. But how that came about is another story.

## Notes

- a. The term “synoptic,” from the Greek for “seeing together,” refers to the fact that the gospels of Matthew, Mark and Luke share much material and can be printed in three parallel columns so that their correspondence can be “seen together” at a glance, as in the first sidebar to this article.
- b. Acts is universally recognized as a continuation of Luke, by the same author.
- c. According to John 1:28, this took place at “Bethany beyond the Jordan.” I suspect that the name “Bethany beyond the Jordan” is an invention of one of the editors of the Fourth Gospel, who assumed that since the Baptist had an audience, there must have been a town. The complete disappearance of a town with this name in little more than a century—Origen could find no trace of it not long after 231 A.D. (*Commentary on John* 6.204)—is highly suspicious to anyone aware of the tenacity of place-names in the Middle East.
- d. It is probable that in John’s source the first disciples of Jesus were directed to him by John. A later editor transformed this into the Baptist’s proclamation of Jesus as the Lamb

of God. The inherent probability of the scenario in John's source is underlined by its similarity to the traditional approach of Old Testament prophets. Elijah selected Elisha as his assistant (1 Kings 19:16–21). Jeremiah chose Baruch to help him (Jeremiah 36). To extend his ministry, John picked out Jesus. With a view to multiplying the latter's effectiveness, it would have been prudent of the Baptist to encourage some of those who came to him to group themselves around Jesus.

- e. We are told that after "following" Jesus (John 1:40) Andrew "first found his brother Simon" (John 1:41), presumably to convert him. The word "first" suggests that Simon is the first in a series, but the expected "He next found X" does not appear in the present form of the gospel. In the original story Andrew must have called someone in addition to his brother, presumably Philip, who was also from Bethsaida (John 1:43–44). The story was edited into its present form to give the initiative to Jesus, who challenges the disciples (John 1:38). It is Jesus who tells Philip to "follow me" (John 1:43).
1. I published an earlier version of this hypothesis as "John the Baptist and Jesus: History and Hypotheses," *New Testament Studies* 37 (1990), pp. 359–374.
  2. The theoretical possibility that the testing of Jesus ended the very day that John was taken into custody is excluded by John 3:22–24, which implies that Jesus had been recruited by the Baptist as his collaborator and exercised a baptizing mission in Judea. I shall return to this text after we have looked at the account of the baptism of Jesus by John because it is indispensable for a correct understanding of the relationship between the two figures.
  3. See Robert L. Webb, "John the Baptist and His Relationship with Jesus," in *Studying the Historical Jesus. Evaluations of the State of Current Research*, ed. Bruce Chilton and Craig A. Evans, *New Testament Tools and Studies* 19 (Brill: Leiden, 1994), pp. 179–229, particularly p. 216.
  4. For example, Raymond A. Martin, *Studies in the Life and Ministry of the Historical Jesus* (Lanham: University Press of America, 1995), p. 25.
  5. Paul Hollenbach, "The Conversion of Jesus: From Jesus the Baptizer to Jesus the Healer," in *Aufsreig und Niedergang der römischen Welt II*, 25/1, ed. W. Hasse (Berlin: De Gruyter, 1982), p. 199.
  6. James M. Robinson, *A New Quest of the Historical Jesus*, *Studies in Biblical Theology* 25 (London: SCM, 1959), p. 118.
  7. *A Student Map Manual. Historical Geography of the Bible Lands* (Jerusalem: Pictorial Archive, 1979), section 12–5.
  8. Josephus *Jewish War* 3:44.
  9. Ben Meyer, *The Aims of Jesus* (London: SCM, 1979) p. 118.
  10. John did not intend to present himself as Elijah; see especially J.A.T. Robinson, "Elijah, John and Jesus: An Essay in Detection," *New Testament Studies* 4 (1957–1958), pp. 264–265.
  11. The name and location of Salim are attested as early as the Septuagint translation of Genesis 33:18, which is confirmed by Jubilees 30:1 and Judith 4:4. The continuity of name and location is clear in a medieval Samaritan chronicle. See Elkan N. Adler, "Une nouvelle chronique samaritaine," *Revue des Etudes Juives* 44 (1902), pp. 207, 212. The references are discussed by M.E. Boismard, "Aenon près de Salem (Jean, iii, 23)," *Revue Biblique* 80 (1973), pp. 219–221.
  12. The name is preserved in Khirbat Ainun, "the ruin of the springs" (Israeli grid map reference 1897/1875), which is located just over seven miles northeast of Salim. The site,

however, has no springs! William Foxwell Albright suggested that the village had moved from its original site between the powerful perennial springs of En Farah and En Duleib (Israeli grid map reference 1883/1825), which had given its name. (“Some Observations Favoring the Palestinian Origin of the Gospel of John,” *Harvard Theological Review* 17 [1924], p. 194.) These springs are beside Tel el-Farah and three miles from Khirbet Ainun, and Albright could suggest no reason for the transfer of the village. Roland de Vaux remedied this defect in Albright’s hypothesis by pointing out that the springs had been the home of the malarial mosquito and that the villagers must have migrated to higher ground for health reasons, while retaining the old name. (Oral communication to Boismard, “Aenon,” p. 222). This explanation, however, defeats its purpose. If the springs and pools at the original Ainun were malaria-infested, it is extremely improbable that John would have chosen it as his base of operations. Why would anyone have taken the risk of immersion there?

13. The decisive objection to the identification of the original Ainun with Aenon is its relationship to Salim. They are only seven miles apart, but those seven miles include two mountain ranges, Jebel Tammun and Jebel el-Kabir, and the impassable upper section of the Wadi Faria/Nahal Tirza. Not surprisingly, there is no direct path between Ainun and Salim. Finally, in the first century the nearest villages to Ainun were Baddan (today Khirbet Farwa) to the southwest and Thebez (today Tubas) to the northeast.
14. Since the site of Salim is certain, it would seem more profitable to look for springs in its immediate vicinity.
15. George Ernest Wright, *Shechem. The Biography of a Biblical City* (New York/Toronto: McGraw-Hill, 1965), appendix 4 by Robert Bull, pp. 217–218.
16. “The final end of Shechem as a city could not have been much later than about 100 B.C.” (Wright, *Shechem*, 171).
17. See the Mishnah tractates *Shebiith* 9:2; *Ketuboth* 13:10; *Baba Bathra* 3:2.
18. C. Saulnier, “Herode Antipas et Jean le Baptiste. Quelques remarques sur les confusions chronologiques de Flavius Josephe,” *Revue Biblique* 91 (1984), pp. 362–376.
19. See the genealogical chart in Ben Witherington III, “Herodias,” in *The Anchor Bible Dictionary*, David Noel Freedman, ed., vol. 3, p. 175.
20. The marriage of a woman with her nephew was also excluded (Leviticus 18:13); the Essenes logically inferred that a marriage between a man and his niece was thereby also condemned (Damascus Document 5:8–11).
21. That is how Josephus reported them (*Antiquities* 18:117–19). The explanations of the Gospels and Josephus are not contradictory but complimentary; see in particular Harold Hoehner, *Herod Antipas* (Cambridge: Cambridge Univ. Press, 1972), pp. 140–145.
22. Josephus *Antiquities* 17:341
23. Josephus *Antiquities* 18:109–119
24. Luke, for example, attributes Paul’s undignified departure from Damascus to Jewish hostility (Acts 9:23–25), whereas Paul himself tells us that the threat came from the Nabateans (2 Corinthians 11:32–33).
25. The evangelist decided to use this information as the introduction to his narrative of the execution of the Baptist (Mark 6:17–29//Matthew 14:3–12//Luke 3:19–20), and into the middle of the phrase he inserted, “Some said, ‘John the Baptizer has been raised from the dead; that is why these powers are at work in him.’ But others said, ‘It is Elijah.’ And others said, ‘It is a prophet, like one of the prophets.’” It was important to the editor to identify John explicitly, and to make it clear that the “has been raised” of the source referred to resurrection. To this end, Mark drew on the list of preserved in his gospel at 8:28: “Jesus

asked his disciples, ‘Who do people say that I am?’ And they told him, ‘John the Baptist; and others say Elijah; and others say one of the prophets.’” Mark also attempted, rather ineptly, to link the material of the source with the preceding episode (Mark 6:6–13) by adding “these powers are at work in him.” It was Jesus who had commissioned the wonder-working apostles and so must have enjoyed the same powers. Neither Josephus nor the Synoptic Gospels, however, depict John as a miracle-worker. The Fourth Gospel explicitly denies that John performed miracles—“John did no sign” (John 10:41).

### *Jesus’ Baptism: Three Views*

Matthew 3:13–17

(13) Then Jesus came from Galilee to the Jordan, to John, to be baptized by him. (14) John would have prevented him, saying, “I need to be baptized by you, and do you come to me?” (15) But Jesus answered him, “Let it be so now; for thus it is fitting for us to fulfill all righteousness.” Then he consented.

(16) And when Jesus was baptized, he went up immediately from the water,

and behold the heavens were opened, and he saw the Spirit of God descending like a dove and alighting on him. (17) And behold a voice from the heavens, saying, “This is my beloved Son, with whom I am well pleased.”

Mark 1:9–11

(9) In those days Jesus came from Nazareth of Galilee,

and was baptized by John in the Jordan. (10) And immediately coming up out of the water,

he saw the heavens opened, and the Spirit as a dove descending on him. (11) And a voice came from the heavens, “You are my beloved Son, with you I am well pleased.”

Luke 3:19–22

(19) When Herod the tetrarch, who had been reproved by him for Herodias, his brother’s wife, and for all the evil things that Herod had done, (20) added this to them all, that he shut up John in prison.

(21) Now when all the people were baptized,

and when Jesus also had been baptized,

and was praying the heaven was opened, (22) and the Holy Spirit descended on him in bodily form, as a dove. And a voice came from heaven, “You are my beloved Son, with you I am well pleased.”

## *Did Jesus Replace John the Baptist?*

Matthew 14:1-2

(1) At that time Herod the tetrarch heard the report about Jesus

(2) and he said to his servants, "John the Baptist has been raised from the dead; that is why these powers are at work in him."

Mark 6:14-16

(14) And King Herod heard, for Jesus' name had become known,

and some said "John the Baptizer has been raised from the dead; that is why these powers are at work in him."  
(15) But others said, "It is Elijah." And others said, "It is a prophet, like one of the prophets." (16) Hearing, Herod said,

"John, whom I beheaded, has been raised."

Luke 9:7-9

(7) Now Herod the tetrarch heard

of all that was done and he was perplexed for it was said by some that John had been raised from the dead; (8) by others that Elijah had appeared and by others that one of the old prophets had risen. (9) Herod said,

"John I beheaded, but who is this about whom I hear such things"? And he sought to see him.

## The Galilee Boat—2,000-Year-Old Hull Recovered Intact

By Shelley Wachsmann

---

**A** severe drought gripped Israel in 1985 and 1986. The winter rains barely came. Water was pumped from the Sea of Galilee to irrigate parched fields throughout the country. Predictably, the Kinneret (the Hebrew name of the freshwater inland lake also known as the Sea of Galilee) shrank. Wide expanses of lakebed, normally covered with water, were exposed.

Moshe and Yuval Lufan live with their families on Kibbutz Ginnosar on the northwest shore of the lake. Avid amateur archaeologists, Moshe and Yuval frequently explored the newly exposed lakebed for ancient remains.

In January 1986 they were examining an area south of the kibbutz, where a tractor stuck in the mud had churned up some ancient bronze coins. Nearby they



Courtesy Israel Dept. of Antiquities and Museums/Photo: Danny Friedman

*The Galilee boat, resurrected after being buried in lake mud for some 2,000 years, makes its 550-yard voyage to the Yigal Allon Museum at Kibbutz Ginnosar. Subsequently, a crane lifted the boat ashore. The conservator, Orna Cohen, had decided that the sea provided the best means for transporting the 26-foot-long boat from the excavation site to the museum. The boat was wrapped in buoyant polyurethane for protection.*

*Based upon the boat's construction techniques, associated artifacts and radiocarbon dates, the boat has been dated to between the first century B.C. and the late first century A.D. It is probably the type of boat that was used by Jesus and his disciples in their many travels upon the Sea of Galilee and by the Jesus in the nautical battle of Migdal.*

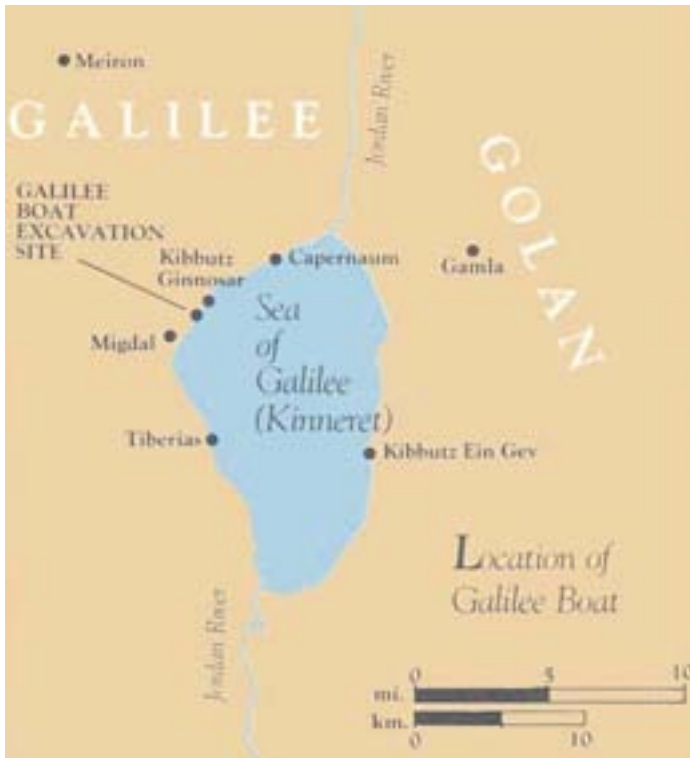

Map showing location of Galilee boat.

found a few ancient iron nails, and shortly afterwards they saw the oval outline of a boat, entirely buried in the mud.

Of course it could have been a 19th or 20th-century boat as easily as an ancient one. The brothers asked their father, a fisherman of 20 years, whether he had ever heard of a modern boat sinking anywhere near this site. “No” was his reply. Besides, he pointed out, the boat was buried so deeply in the mud that it must have been there for a very long time.

“Ask Mendel,” was the father’s advice.

Mendel Nun is unique. A member of Kibbutz Ein Gev, on the east side of the lake, Mendel has made the Kinneret—in all its aspects from archaeology to zoology—his specialty. He is widely known as Israel’s number one “Kinneretologist.”

Mendel visited the site, but could offer no opinion as to whether the buried boat was ancient or modern. However, he notified Yossi Stefanski, the local inspector for the Department of Antiquities, of the discovery, and Stefanski in turn notified me as the Department’s Inspector of Underwater Antiquities.

On Tuesday, February 4, 1986, I returned from a coastal survey on the Mediterranean to find a note on my desk—something about a boat, possibly ancient, in the Kinneret. The next day I



Courtesy Israel Dept. of Antiquities and Museums/Photo: Shelley Wachsmann

*Where’s the boat? Buried in the mud beneath Yuval Lufan’s feet, the Galilee boat revealed its presence by a faint oval outline. Lufan and his brother Moshe, both residents of Kibbutz Ginnosar, discovered the boat while combing the Sea of Galilee’s newly exposed lakebed for remains of ancient craft. Consecutive winters of below average rainfall had caused a dramatic drop in the sea’s water level. The mudbed in which the boat was discovered is normally well under water, beyond the reach of amateur archaeologists. Even as the excavation proceeded, the lake returned and threatened to engulf the site. Only the rapid construction of a temporary dike enabled the archaeologists to finish their work.*

drove to Ein Gev with my colleague Kurt Raveh to pick up Mendel; from there we went to meet the Lufan brothers at Ginnosar.

Over coffee and cake, Yuval and Moshe told us about their discovery. Everyone wanted to know whether the boat was ancient.

I explained that ancient boats found in the Mediterranean were built in an unusual way. The planks of the hull were edge-joined with “mortise-and-tenon” joints that were held in place with wooden pegs. This form of construction has been found as early as the 14th–13th centuries B.C. (it was used in the famous Ulu Burun [Kas] wreck, now being excavated off the coast of Turkey) and continued to be used through the Roman period. All we had to do was scrape away the mud from the top of the uppermost strake (as the continuous lines of planks extending from bow to stern are called) to see whether we could find the dark rectangular remains of the “mortise-and-tenon” joints with round dot-like heads of wooden pegs. This would be the telltale sign that the boat was ancient—assuming, of course, that Kinneret boats developed in a parallel fashion to Mediterranean craft.

The five of us bundled into our jeep and drove to the site. Kurt and I quickly excavated a small section at midship. As we carefully removed the mud, “mortise-and-tenon” joints appeared. They were locked with wooden pegs, the round heads easily visible.

The boat was ancient! This was the first time an ancient boat had been discovered in the Kinneret.

In our excitement, we hardly noticed that it had begun to rain. Suddenly, a torrent of water descended on us. We ran for the jeep. It rained for perhaps a minute and then stopped as suddenly as it had begun. We got out of the jeep and saw a beautiful double rainbow cascading into the Kinneret—straight out of Central Casting, a portent of things to come.

*In antiquity, Mediterranean shipbuilders devised the mortise-and-tenon method of joining the hull planks to one another. Instead of overlapping adjacent planks and fastening them together, shipbuilders placed the planks in an edge-to-edge position and joined them by means of wooden links (tenons) inserted in slots (mortises) carved in the two planks. The tenons were then firmly secured within the mortises by pegs through the plank and its tenon. When the craft was placed in water, the wood swelled, forming a watertight fit. This joining technique has been discovered in vessels dated as early as the 14th–13th centuries B.C.; it went out of use in the Byzantine period.*

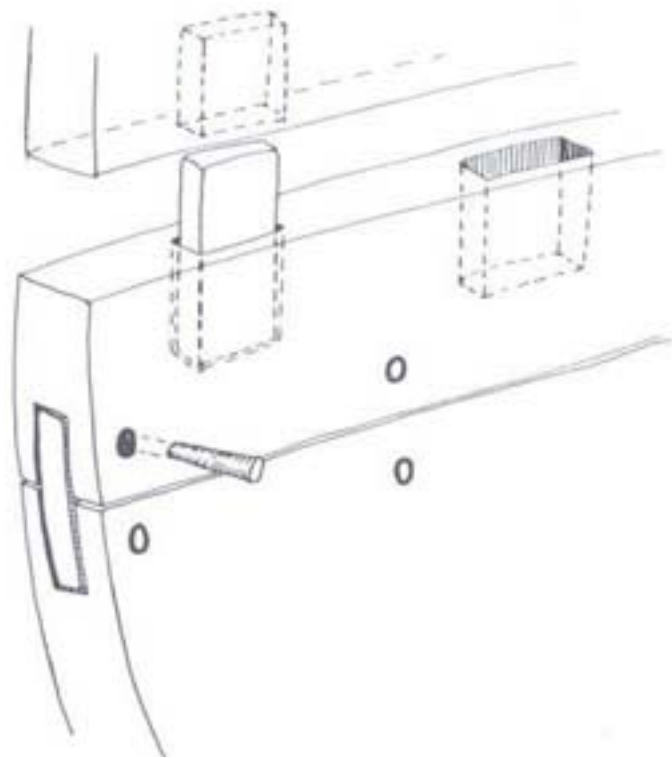

Ronny Reich



Courtesy Israel Dept. of Antiquities and Museums/Photo: Shelley Wachsmann



*When telltale signs of mortise-and-tenon joints appeared, the excavators knew they had found an ancient boat. Two round-headed wooden nails, right and left of center, peek out of a small section of the uppermost plank. In antiquity, Mediterranean shipbuilders devised the mortise-and-tenon method of joining the hull planks to one another (see drawing).*

Tiberias, a large town at the southern end of the lake, soon surrendered to Vespasian. The Romans then built a large fortified camp between Tiberias and Migdal.

The Jews from Migdal, under Jeshua Ben Shafat, carried out a daring raid on the camp that caught the Romans by surprise. When the Romans managed to organize themselves, the Jews effected an orderly retreat, and taking to their boats, rowed out into the lake. When they reached bowshot range, they anchored “phalanx-like” opposite the Romans and engaged them in an archery battle.

The Romans then attacked Migdal, massacring the Jews in the city. Many of the Jews sought to escape by boat. Those who managed to do so took refuge on the lake, keeping as far out of range of the Romans as they could.

The next day, Vespasian ordered craft to be built to pursue the Jews in their boats. These were quickly prepared. Roman archers and infantry armed with swords and javelins were stationed on the Roman vessels, and battle was soon joined with the refugees on the lake.

*A brilliant rainbow arcs across the Galilee sky. Like a favorable portent, the rainbow appeared shortly after the archaeologists verified that the buried boat was ancient.*

Courtesy Israel Dept. of Antiquities and Museums/Photo: Shelley Wachsmann



In the ensuing battle the Jews “were sent to the bottom, boats and all.” Some tried to escape by breaking through the line of Roman vessels, but to no avail. The Romans reached them with their lances or jumped into their boats and killed them with their swords. Those who fell into the water were dispatched with arrows, while any who tried to climb on to the Roman vessels were beheaded or had their arms cut off by the Romans.

The remaining Jewish boats were driven to land, and the shore became a killing field. Describing the aftermath of the battle, Josephus wrote:

“During the days that followed, a horrible stench hung over the region, and it presented an equally horrifying spectacle. The beaches were strewn with wrecks and swollen bodies, which, hot and clammy with decay, made the air so foul that the catastrophe that plunged the Jews in mourning revolted even those who had brought it about. Such was the outcome of this naval engagement. The dead, including those who earlier fell in the defense of the town (Migdal), numbered 6,700.”

I remember thinking that the battle of Migdal was the nautical equivalent of Masada. Was the buried boat we were looking at a wreck that had washed up on that vermillion beach?

During the next two days we carried out a probe excavation around the boat. We opened a few small sections along its length to determine its state of preservation and to try to date it more accurately. During this excavation, we found two pottery vessels: a cooking pot (or casserole) outside the boat and an oil lamp inside it. Both dated to the early Roman Period (mid-first century B.C. to mid-second century A.D.). The link between this pottery and the wreck was illusive because the pottery was not part of the boat’s cargo. Still, these finds did indicate a period of human activity in the immediate vicinity of the boat.

To protect the boat at the conclusion of the probe, we reburied it. Moshe and Yuval brought a tractor from the kibbutz and pushed pieces of jetsam, old pipes and heavy tree trunks around the site so that no one would drive over it accidentally. As an added precaution, they dug two “decoy” excavations farther down the beach to mislead looters and the just plain curious.

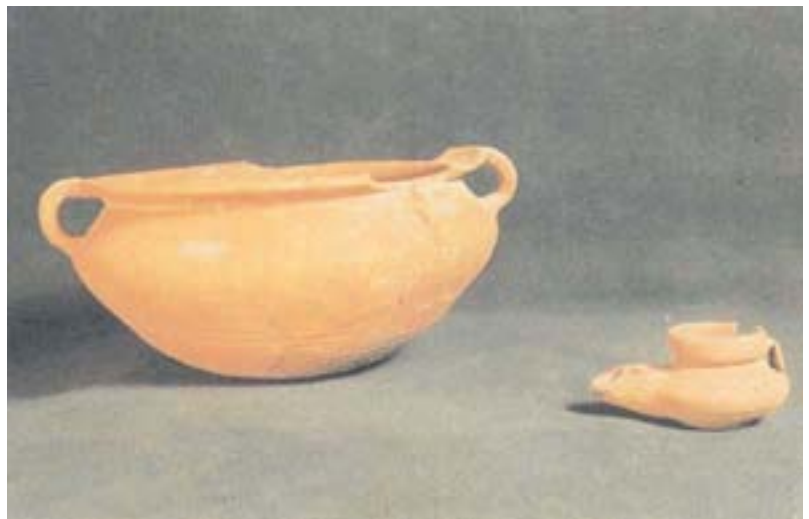

Courtesy Israel Dept. of Antiquities and Museums/Photo: Tsila Sagiv

*Cooking pot, left, and oil lamp. These beautifully preserved pottery vessels date respectively from the mid-first century B.C. to the mid-second century A.D. and from the first to the second centuries A.D. The oil lamp was found inside the boat, and the cooking pot was unearthed just outside the boat.*

The discovery was to be kept secret until the rising waters of the Kinneret safely covered the boat. At that time it would be possible to reveal its discovery and, hopefully, organize a proper excavation.

That was Friday, February 7th. On Sunday, we were startled to read newspaper reports of a wreck from Jesus' time that had been discovered in the Sea of Galilee. Somehow the news had leaked. By Monday the press was writing in front page stories about the discovery of the "boat of Jesus."

The media hype was soon overwhelming. The Ministry of Tourism actively promoted the "Jesus connection" in the hope of drawing pilgrims to Israel. In Tiberias, Ultra-Orthodox Jews, fearful that excavation of the boat would promote Christian missionary work, demonstrated against it.

Soon rumors were circulating that the wreck was full of gold coins. Stories had been making the rounds for years of a ship that sank in the Kinneret during World War I, while carrying payment for the Turkish army. Now our wreck was becoming entwined with these stories, and people began searching for the non-existent treasure.

In Israel it is extraordinarily difficult to keep new archaeological finds hidden. Our boat proved to be no exception. Tuesday night, Moshe and Yuval were watching the site, through field glasses, from Ginnosar. They saw some people with flashlights in the area of the boat. Yuval immediately called me, and I drove to Ginnosar, arriving about midnight. The people had left without finding the boat. The three of us sat in a grove of trees watching the site until 3 a.m. The coast remained deserted. We knew that if we did not excavate the boat soon, there might be no boat to excavate. It was only a matter of time until someone would find and destroy the boat in search of non-existent treasure.

Archaeology throughout the world is dotted with cases of important discoveries destroyed because looters reached them before the archaeologists. We decided we had to excavate the boat immediately despite the fact that the archaeological and organizational logistics were mind-boggling.

A proper excavation takes time to prepare. Funds must be raised, team members recruited and a myriad of details worked out. Months, and sometimes years, go by before a planned excavation goes into the field. We would go into the field in three days.

The next day, February 12, I spent preparing a detailed excavation proposal for the Director of the Department of Antiquities, Avraham (Avi) Gitan. I made one condition concerning the excavation. We could assemble a local team for the archaeological excavation and conservation, but we were lacking someone who could make sense of the boat's construction once it was excavated. For this we would have to bring in someone from outside the country. We contacted Professor J. Richard (Dick) Steffy of the Institute of Nautical Archaeology, Texas A & M University, the world's leading expert on ancient ship construction.

Would he be able to come over on such short notice? If so, how were we going to pay for his trip? We called Dick from Ginnosar. He had already heard about the boat from the newspaper accounts and agreed to spend a week with us from February 20 to 25. Getting a ticket for Dick through governmental channels would be difficult on such short notice. However, the new American ambassador to Israel, Thomas Pickering, was a keen amateur archaeologist, and we wondered out loud whether the embassy might have a cultural grant program that could help in such situations. We contacted the American Embassy, and within 14 hours we had an OK on Dick's flight.

The excavation was on. Its purpose was to excavate the boat, study it *in situ* and move it to the Yigal Allan Museum at Kibbutz Ginnosar for conservation—if possible, in one piece. We were to start on Sunday, February 16.

Before we could begin excavating, however, a new problem arose—literally arose. The lake was threatening to cover the boat again.

Moshe and I walked out to the site on Saturday night. When I had first seen the boat, less than two weeks before, the waterline was about 100 feet east of the site. Now it had advanced to within about 30 feet of the boat—and the forecast was for more rain. If the rain continued, the site would soon be inundated.

On the way back to Ginnosar, Moshe tried to cheer me up by saying that perhaps water was being pumped out of the lake for irrigation purposes. The Kinneret serves as the main reservoir of Israel's fresh water. There are three huge pumps that take water from it to the National Water Carrier.

This gave me an idea that was definitely on the "Far Side." Perhaps it might be possible to lower the level of the lake by pumping water out of it. I knew that Avi Eitan was meeting with the Minister of Education the next day concerning the boat. I phoned him and asked him to pass on a plea to the Minister of Education to ask the Minister of Agriculture to pump water out of the Kinneret into subsidiary reservoirs that would keep the water level steady until we could finish excavating the boat. In a country where raising the level of the Kinneret is a national passion, I doubted that this would be politically feasible, but it was worth a try.

On the day the excavation was to start, we were delayed by an armed band from a nearby settlement that laid claim to the boat. This matter was settled by the police and by a diplomatic effort on the part of the Director of the Department of Antiquities, who quietly explained that all antiquities belong to the state. We had lost half a day.

As we began excavating in the late afternoon, curiosity seekers crowded around, waiting for us to find the "treasure." For the next four hours, we excavated next to the boat. It became dark, and the crowd dispersed.

Then we began digging in earnest. With the lake rising steadily, we decided to work around the clock. Gas fishing-lamps lit up the area with an eerie, warm yellow glow. Work went slowly as we removed the mud from inside the boat, being careful to leave a 6-inch layer of mud covering the wood.

The excavation team slowly formed. Orna Cohen was to be our conservationist; Danny Friedman joined as our photographer. Edna Amos, an archaeologist who had worked previously with Kurt and me in the Mediterranean, heard about the project during that first afternoon of excavation and dropped by to say hello. I immediately drafted her as our recorder. Edna worked through that night till 6 o'clock the next morning and returned the next day to become our permanent recorder.

During the evening we received a visit from members of the Kinneret Authority, the governmental body responsible for the lake. They had received a strange message from the Minister of Agriculture—to lower the level of the lake. They assumed that the message had been scrambled—no one in his right mind would want to lower the level of the lake.

I laughed and explained our predicament. They came up with a way to save the site, however, without lowering the level of the lake: Build a massive dike around the site to protect it from the encroaching lake. They promised to return the next morning with workers and supplies.

During the night we cut a narrow section down to the wooden hull at midship. Lying on our stomachs in the cold, wet mud, we excavated it by hand to avoid any possibility of damage to the boat from instruments. The wood slowly appeared; it was beautifully intact.

It was obvious, however, that in excavating clumps of mud in the dark we might miss artifacts. For that reason, all the mud excavated inside and next to the boat was placed in plastic boxes, which were given basket numbers and their positions recorded. The boxes were dumped in numbered piles that were later examined for artifacts. Moshe found an ancient pyramidal arrowhead in this way. More about this later.

Shortly after 6 a.m. Monday morning, the wind suddenly shifted to an easterly. It began pushing the water toward the boat. But it was not long thereafter that the Kinneret Authority team arrived, like the proverbial cavalry, and began building a dike of earthworks and sandbags around the site to protect it from the rising water. The site



Courtesy Israel Dept. of Antiquities and Museums/Photo: Danny Friedman

*The boat emerges from the muck, on the first night of digging. The drought had broken, and forecasts were calling for more rain. Racing the rising lake waters, the team of experts and local volunteers was forced to work day and night. By digging at night, however, they risked damaging or losing smaller artifacts not visible in the warm yellow glow of gas lanterns, their only light source. To avoid any oversights, they removed mud by hand and placed it in plastic boxes precisely labeled according to location. Then, by daylight, they could examine the earth for artifacts.*



*Bird's-eye view of the boat on the second day of excavation. Between the two excavators, at midship line on the far side of the boat, a narrow section of mud was cut out, down to the wooden hull.*

be exhibited were laid aside as we all pulled together in a concerted effort to save the boat. Because of this new-found harmony, we nicknamed it “the Love Boat.”

On the second day of the excavation, as we were widening the excavation pit with a backhoe (lent by a moshavnik from Migdal), Zvika Melech, another moshavnik, showed



*Suspended above the boat from two bridges of metal poles, wooden planks provided a useful, if uncomfortable, platform from which workers could excavate without touching the fragile, waterlogged timbers. The bridges also supported a white tarpaulin that shielded the boat from direct sunlight, which might otherwise cause the wood to dehydrate and disintegrate.*

was saved from the encroaching water. Although the lake continued to rise, there was no longer a problem of water.

It is impossible to describe the effect the excavation had on everyone involved. Kibbutz Ginnosar “adopted” the excavation, supplying volunteers and logistics. The kibbutzniks would finish their own day’s work and then join us for another eight or ten hours at night. Volunteers arrived from all over the country. The excitement was infectious. By the second afternoon, members of Moshav Migdal had also joined us. Previous arguments about where the boat would

me some pieces of waterlogged wood. We could not stop using the backhoe because enlarging the pit was our top priority, but now each shovel load had to be dumped in front of us and examined. We removed the loose pieces of waterlogged wood. The shovel load was then dumped on the side of the pit where Moshe, using a metal detector, removed iron nails. Suddenly sticking his hand into the pool of water, Zvika yelled, “This

wood is connected to something!” Zvika had found what Dick Steffy later identified as fragments of two additional boats. The boat fragments were sandbagged, and we began excavating there by hand. Zvika, of course, was put in charge of the area.

On the second evening of excavation, the upper part of the partially excavated stern on the starboard quarter of the boat buckled. We had dug too far on either side without supporting it sufficiently. Someday, when the boat is reconstructed, those timbers will be refitted to the boat. But that evening was one of the worst I can remember. We all felt that despite our best efforts the boat was falling apart.

In order to avoid touching the fragile wood while excavating, Moshe built a series of metal bridges, on which the excavators could lie, over the boat. As the excavation progressed, the bridges were raised, and a platform suspended on ropes was lowered from it. Excavators lay prone on this platform for hours as they dug out the remaining mud by hand.

Each part of the boat was tagged and numbered. White plastic tubing was used to outline the strakes to enhance photographic recording. By the time Dick Steffy arrived on the fifth day of excavation, much of the hull had been exposed. Dick’s presence at the excavation site gave us all a feeling of security. His vast knowledge and good common sense were invaluable.

At the conclusion of a normal excavation, the excavator gives a few boxes of artifacts to the conservationist. But in our case, the boat itself was one big conservation problem. At the beginning of the excavation I had called in Orna Cohen, an archaeologist turned conservator, who had just returned from a year of studies in England to take charge of this problem.

By the eighth day of excavation, the archaeological aspects of the excavation had been completed. Now the question was how to move the boat. It was Orna’s ball game.

The craft’s wooden timbers were thoroughly water-logged. This meant that the cellular material inside the wood cells had been replaced with water to the degree that the



Courtesy Israel Dept. of Antiquities and Museums/Photo: Danny Friedman

*Dotted with numbered tags, all the wooden sections were meticulously labeled to record their correct locations. Running lengthwise across the boat, white plastic strings outline the planking structure. A dangling sprinkler, brought from Kibbutz Ginossar, sprayed the boat continually to prevent it from drying out. The wood’s micro-structure was supported mainly by water. Any evaporation would lead to the wood’s collapse.*



Lush planted fields meet the shore of the Sea of Galilee. At upper left stands the Yigal Allon Museum—a tall white building at the water’s edge—where the Galilee Boat is now housed. When this photo was taken, the boat still lay on shore under a tarpaulin, the white speck at center, 550 yards to the right of the museum.

Throughout the complex excavation and transportation of the boat, the two nearby agricultural communities, Kibbutz Ginnosar and Moshav Migdal, enthusiastically volunteered both workers and equipment.

never been tried before. She decided to strengthen the boat inside and out with a fiberglass-and-polyester resin frame molded to the shape of the hull. The entire boat would then be encased in a polyurethane foam “straight jacket” to hold it together. We were going to attempt to move the boat intact.

First, frames of fiberglass/polyester (strengthened with old pieces of PVC irrigation hose) were laid down inside the boat. Then the entire hull was covered with fine plastic sheeting, and polyurethane foam was sprayed into the hull. This material sprays on as a dark orange liquid and quickly bubbles up and solidifies, looking every bit like a living entity engulfing the boat.

Next we excavated narrow tunnels under the boat. External fiberglass frames were then molded to the outside of the hull and the tunnels were filled with polyurethane. These polyurethane strips hardened into external supports for the boat. This allowed the remaining clay and mud beneath the boat to be excavated. Fiberglass trusses were again added and the remaining areas were filled with polyurethane. By the end of the process, the entire boat—without having been moved or shifted—had been wrapped in a protective cocoon that looked somewhat like an overgrown, melted marshmallow.

wood, according to Orna’s study, was now 80 percent water and had the consistency of wet cardboard. Any evaporation of water from such wood is extremely dangerous, causing the cell walls to collapse. This process is irreversible; the wood shrinks and fragments, and it cannot be restored to its former structure. Because of such dangers during the excavation, we sprayed the boat with water day and night, and even covered it with wet sponges and polyethylene sheets, in addition to shading it from direct sunlight.

Moving an entire boat of such soft material was a nearly impossible mission—and yet we had to move it approximately 1–600 feet to the Yigal Allon Museum at Kibbutz Ginnosar.

Orna consulted experts on the transport of large objects. It seemed that it was impossible to move a 26 foot-long boat of such fragile wood without seriously damaging it.

But Orna devised a method that had



Now that it was packaged, how would we move it? We considered carrying it overland by truck or helicoptering it out, but the related movement and vibrations were likely to destroy the boat. In the end, Orna opted for the obvious solution.

Once the boat was “packaged,” we pumped water back into the excavation pit. Buoyed by the polyurethane, the boat floated at lake level. With a steam shovel, a channel through our precious dike was opened to the lake. The boat was floated through this channel out into the lake. For the first time in two millennia, the boat “sailed” again to the cheers of an onlooking crowd.

Courtesy Israel Dept. of Antiquities and Museums/Photo: Danny Friedman



*Protected by a polyurethane cocoon, the Galilee Boat floats again, for the first time in 2,000 years. The 550-yard voyage to the Yigal Allon Museum required extensive preparation. Conservator Orna Cohen of Hebrew University planned and supervised the construction of fiberglass and polyester resin frames, fitted inside and outside the boat’s hull. The boat was then wrapped in thin plastic sheeting and sprayed with polyurethane liquid, which hardened into a protective shell. Completely encased, the boat was ready to float.*

*After a steam shovel, right, cut a channel through the dam that had been built to protect the excavation site from rising water, the Galilee boat sets out on its last voyage.*

breakage. But the boat was now drying out at an alarming rate, no matter how much we sprayed it with water. As time passed, it seemed we were losing the battle. Hairline cracks began to appear. I felt like a doctor about to lose his patient at the end of an extensive operation.

In what was surely the 11th hour, we finally finished the re-excavation of the boat and submerged it in water—and we ourselves nearly dropped from exhaustion.

The entire excavation had taken eleven exhausting days and nights.

The next day, the boat was lifted onto the shore by a huge crane. Within ten days thereafter, a reinforced concrete pool with white tiles was constructed to serve as the boat’s conservation tank. The boat was then raised once again by crane and placed inside the empty conservation pool.

Now began the long and laborious task of removing the polyurethane casing—tantamount to re-excavating the boat. We had not thought of putting trip-wires inside the polyurethane casing; we paid dearly for this mistake. In the tight confines of the conservation pool, the re-excavation was doubly difficult.

We could not fill the conservation pool with water and submerge the boat until all the polyurethane had been removed; otherwise, some parts of the boat would strain to float and the stress would cause

The boat will now be treated for a period of five to seven years. A synthetic wax called PEG (polyethylene glycol) will be added to the water in slowly increasing concentrations. Simultaneously, the temperature of the water will be gradually raised. In this way, the PEG will penetrate the cellular cavities of the deteriorated wood and replace the water in the cells. At the conclusion of this years-long process, we will be able to exhibit the boat outside the conservation pool and study it in a dry environment. In the meantime, entrepreneurs from Kibbutz Ein Gev and from Tiberias are ferrying tourists across the lake to see “the boat from Jesus’ time.”

It does seem that the boat fits this time range and is of the type that would have been used by Jesus and his disciples.

I have already mentioned the pottery that gave us a general idea of the date of the boat. Dr. David Adan-Bayewitz of Bar-Ilan University, who studied this pottery, considerably narrowed the time range.

By comparing the datable pot sherds found in the excavation to nearby stratified assemblages, he concluded that the pottery found with the boat is typical of the latter part of the first century B.C. to the decades following the mid-first century A.D., or until about the year 70 A.D. As noted previously, this pottery does not date the boat directly; however, it does indicate a period of human activity in the immediate area of the boat. This period appears to end at the time of the First Jewish Revolt against Rome and may be related to the decimation of the population of Migdal at that time.

It therefore seems likely that the boat arrived at the site prior to the battle of Migdal.

Wood from the boat itself was dated by the carbon-14 method.<sup>a</sup> Dr. Israel Carmi of the Department of Isotope Research of the Weizmann Institute carried out analysis on ten samples of wood from the boat and arrived at an average date of 40 B.C., plus or minus 80 years; that is, from 120 B.C. to 40 A.D.<sup>b</sup>

Dick Steffy independently came to about the same conclusion based on his knowledge of ancient boats. In his hand-written report to the Director of the Department of Antiquities, Dick wrote: “If this were a hull found in the Mediterranean I would date it

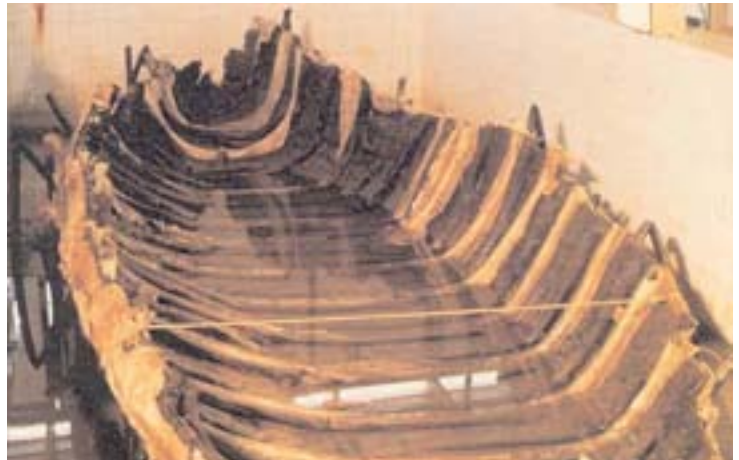

*Ribs of wood lie bare in the boat's specially built concrete conservation pool. Once inside the pool, the boat had to be stripped of its casing—an excavation in itself. Having outsmarted the Sea of Galilee's encroaching waters, the team now had to work furiously to remove the protective shell before the wood dried out. The boat could be re-immersed only after every shred of polyurethane had been taken off, because the buoyancy of the polyurethane would cause the parts of the boat underwater to rise. This would dangerously strain the boat's fragile frame.*

Courtesy Israel Dept. of Antiquities and Museums/Photo: Danny Friedman

between the first century B.C. and the second century A.D.” He noted, however, that building traditions may have continued in the Kinneret after they had gone out of use in the Mediterranean.

Admittedly, each of the dating methods is insufficient in itself; however, taken together, these different dating techniques suggest a date between the first century B.C. and the late first century A.D.

Dr. Ella Werker of the Department of Botany at Hebrew University examined the wood from which the boat was made. This examination revealed that while most of the boat was constructed of cedar planking and oak frames, there are five other woods represented by single examples. These are: sidar, Aleppo pine, hawthorn, willow and redbud.

The boat is 26 ½ feet long, 7 ½ feet wide and 4 ½ feet high. It has a rounded stern and a fine bow. Both the fore and aft sections were probably decked in, although the boat was not preserved to this height.

Dick Steffy’s study of the boat suggests that it had been built by a master craftsman who probably learned his craft in the Mediterranean or had been apprenticed to someone who had. But he had to use timber that was far inferior to what was used on Mediterranean vessels. Perhaps better materials were beyond the financial reach of the owner. Many of the timbers in our boat, including the forward portion of the keel, were apparently in secondary use, having been removed from older boats.

The boat must have had a long life, for it had been repeatedly repaired. It ended its life on the scrap heap. Its usable timbers—including the stempost and sternpost—were removed; the remaining hull, old and now useless, was then pushed out into the lake where it quickly sank into the silt.

Did the boat have a mast? Steffy’s careful detective work demonstrated that it did. A mast cannot be placed directly on a hull. It normally sits on a construction of wood called a mast step. This may be a simple block of wood or a complicated construction. Steffy found four nail holes where the mast block had been connected to the keel. The impression of the mast block was still visible on the top side of the keel. The mast block, like so many other reusable parts of the boat, had been removed in antiquity.

The boat could thus be both sailed and rowed. It was probably used primarily for



Courtesy Israel Dept. of Antiquities and Museums/Photo: Danny Friedman

*Protruding from the mud, the stern end of the boat’s keel terminates in a notch, called a hook scarf, left. Missing is the sternpost, which originally attached to this wooden locking connection. The sternpost was carefully removed in antiquity for reuse in another boat, just as spare parts today are scavenged from old cars.*

fishing, but could also serve for transportation of goods and passengers. During times of armed conflict, it could serve as a transport.

The recovery of an ancient arrowhead in the excavation may indicate that a battle took place in this area. Arrowheads of the same pyramidal design have been recovered outside and next to the walls of Gamla on the Golan heights, another site where, despite an initial Jewish military success, the Romans successfully routed Jewish defenders, after a battle that ended in bloody disaster.<sup>c</sup> Danny Friedman, our photographer, who also works at Gamla, studied the pyramidal arrowhead found at our site. This type of arrowhead is apparently of foreign origin and was probably a specialty of a foreign auxiliary archer unit attached to the Roman legions. (Only 14 of approximately 1600 arrowheads found at Gamla are of this type.)

The fact that fragments of two other boats and other wooden debris were found during the excavation suggests to Dick that the area was used for building and repairing boats. This conclusion is also supported by the circumstance that before our boat was sunk, parts that might be used in other boats were removed—much like an old car today might be kept near a garage to serve as a source for used parts.

Was our boat typical of the kind referred to so often in connection with Jesus and his disciples in the Gospels and in Josephus' description of the battle of Migdal?

During the excavation, Dick had suggested that there were probably four rowers on a boat like ours.

At first this seemed to be contradicted by a mosaic picture of a boat found at Migdal. The mosaic shows a boat that apparently had three oars on each side. But when I examined the Migdal mosaic boat more closely I discovered that the two forward oars were represented as a single line of red tesserae (mosaic stones) that stood out against the black and white hull; but the sternmost oar widened at the bottom—it was a steering oar. The boat in the mosaic must have had four rowers, as Dick had predicted for our boat, and a helmsman—a crew of five.



Courtesy Israel Dept. of Antiquities and Museums/Photo: Danny Friedman

*Oars poised, a boat in a first-century A.D. mosaic remains forever at sea. Decorating a house in the Galilee seaside town of Migdal, only a mile from the discovery site of the Galilee boat, the mosaic boat appears to be propelled by six oars, three on each side. However, the sternmost oar widens at its base and therefore should be interpreted as a steering oar, or quarter rudder. Thus, this mosaic boat may resemble the Galilee boat, which probably had four rowers (two on each side) and a helmsman who steered with the quarter rudder.*

Then I reexamined some passages in Josephus in which he describes how, when he was commander of the Jewish rebel forces in Galilee, he put four sailors in each of the boats; elsewhere he talks of a helmsman—thus each boat again had a crew of five.

How many people could our boat hold? In one passage in Josephus he refers to himself, some friends, and seven combatants in a boat, which, with a crew of five, would total at least 15. In another passage, he tells of ten men of Tiberias who were transported in a single “fishing boat.” With a crew of five, this too would total 15 men.

Based on skeletons he has examined, Joe Zias, a physical anthropologist at the Department of Antiquities, estimates that, in the Roman-Byzantine period, Galilean males were about 5 feet, 5 inches tall and averaged about 140 pounds. Fifteen such men would weigh just over a ton and could fit into our boat.

A boat like this could easily accommodate Jesus and his disciples, who regularly used boats on the Sea of Galilee (See Matthew 8:18, 23–21, 9:1, 14:13–14, 22–32, 15:39, 16:5; Mark 4:35–41, 5:18, 21, 6:32–34, 45–51, 8:9–10, 13–14; Luke 6:1, 8:22–25, 37, 40; John 6:16–21.) The gospel passages do not indicate precisely, however, how many disciples were in the boat with Jesus during the recorded boat trips on the Sea of Galilee.

While the Gospels do not help in defining passenger capacities, there are two references to crew sizes.

Jesus called James and John, the sons of Zebedee, while they were in their boat tending their nets “and they left their father Zebedee in the boat with the hired servants, and followed him” (Mark 1:20). Thus, the boat of the Zebedee family was crewed by at least five men (Zebedee, James, John and two or more hired servants).

In mid-April 1987, over a year after the conclusion of the excavation, I wrote to Dick, suggesting this working hypothesis: The Kinneret Boat represents a class used on the lake during the Second Temple period. This is apparently the same class described by Josephus and in the Gospels and represented in the Migdal Mosaic.

Dick replied:

“Your working hypothesis sounds okay, but may I make a further suggestion? Shell construction limited design possibilities, so there probably were not as many different boat designs on the Kinneret in antiquity as there are today. I suspect there were small boats—rowboats for one or two fisherman—and big boats such as ours. They may have varied somewhat in appearance and size, but basically they must have been limited to a couple of different hull forms in any given period. Without propellers to push them along, it seems unlikely that boats much larger than ours would have been practical on such a small body of water.”

Is there any historical evidence for the smaller boat types that Dick postulated? Perhaps. Small boats may be inferred from another story Josephus tells about his adventures in Tiberias.

Pursued by an angry crowd, Josephus and two of his bodyguards “advanced to the rear” by commandeering a boat moored nearby and making a dash for it. Considering the speedy exit, it seems likely that they had taken a smaller type of boat.

Mendel Nun explained to me that boats of similar size to our boat were still in use on the Kinneret at the beginning of the 20th century—prior to the introduction of the motor. Known as *Arabiye*, they were used with a seine net. This type of net, used for catching shoals of fish near shore requires a boat 20 to 25 feet long. The net is spread out with its ropes as the boat advances. The net varies in size from about 500 to 1500 feet long, and requires a large stern platform to handle. Known as a *sagene* in Greek, this type of net is referred to by Jesus in the parable in which he compares heaven to a net:

“Again, the kingdom of heaven is like a net which was thrown into the sea and gathered fish of every kind; when it was full, men drew it ashore and sat down and sorted the good into vessels but threw away the bad. So it will be at the close of the age. The angels will come out and separate the evil from the righteous” (Matthew 13:47–50).

Because a boat that uses this kind of net requires a large stern platform, this might enable us to picture more accurately the episode in which Jesus stilled the waters of the Sea of Galilee. A storm arose while Jesus with some of his disciples was crossing from one side of the lake to the other. In Mark’s version of the story, Jesus was “in the stern, asleep on the pillow” (Mark 4:37). The large stern deck may explain why Jesus chose the stern in which to sleep. The stern deck was the station of the helmsman. While it would have been exposed to the elements, the area under the stern platform would have been the most protected area of the boat. Jesus probably slept beneath the stern platform. There he would have had the greatest protection from the elements and been out of the way of the other people on board:

“And a great storm of wind arose, and the waves beat into the boat, so that the boat was already filling. But he was in the stern, asleep on the pillow; and they woke him and said to him, ‘Master, do you not care if we perish?’ And he awoke and rebuked the wind and said to the sea, ‘Peace! Be still!’ And the wind ceased, and there was a great calm” (Mark 4:37–39).

More than a century ago, it was noted that the definite article used in relation to the pillow indicates that this was part of the boat’s equipment. This may have been a sandbag used for ballast. Such ballast sacks were used on sailboats in the Mediterranean that used the seine net. There were two types of these: one, weighing 110–130 pounds, called in Arabic *kiÆs s\aubuÆra* which means “balance (or ballast) sack;” or two sandbags of about 55 pounds each, used together. The latter was called a “balance (or ballast) pillow” (Arabic: *meh\adet s\aubuÆra*).

These sandbags were used to trim the boat when under sail; when not in use, they were stored beneath the stern deck where they could be used as pillows by crews resting there.

In conclusion, the Kinneret Boat is of the class referred to both in the Gospels in relation to Jesus' ministry in the Sea of Galilee region, and by Josephus in his description of nautical warfare on the lake during the First Jewish Revolt against Rome.

At present we have no proof that our boat played any part in these momentous events. But it does allow us better to understand them and seafaring on the Kinneret nearly 2,000 years ago.

## Notes

- a. For an explanation of the carbon-14 method of dating, see the box above.
  - b. However, the carbon-14 test tells us when the wood was cut. Some of the wood on this boat may have been reused from hulls of earlier boats.
  - c. See "Gamla: The Masada of the North," **BAR** 05:01 and Flavius Josephus, "The Fall of Gamla," **BAR** 05:01.
- 
1. David Adan-Bayewitz and Isadore Perlman, "Local Pottery Provenience Studies: A Role for Clay Analysis," *Archaeometry* 27 (1985), pp. 203–217; Adan-Bayowitz, *Common Kitchen Ware in Roman Galilee: A Study of Local Trade* (Ramat-Gan, Israel: Bar-Ilan University Press, in press).

## *Dating the Pottery from the Galilee Boat Excavation*

By David Adan-Bayewitz

---

Seventeen identifiable pieces of ancient pottery—including a complete lamp and cooking pot, as well as fragments of cooking pots, storage jars, a jug and juglets—were recovered from the Galilee boat and from the surrounding area during the excavation. The pottery was not significantly water-worn, so we assume that the pieces were deposited near the places where they were found.

The pottery types recovered are all known from other Galilee excavation sites. Several of the more common types were made at Kefar Hananya, a Galilean pottery manufacturing center of the Roman period, located about 8 ½ miles northwest of the boat site.<sup>1</sup>

None of the pottery is necessarily related to the hull itself; hence it cannot be used to date the boat. To date the boat, only intrinsic evidence may be used: evidence such as the carbon-14 dates obtained for the wood, and the method of vessel construction. However, the pottery recovered during the excavation is significant for estimating when there was activity in the vicinity of the boat.

The pottery pieces found near the Galilee boat were the same types as pottery recovered in excavations at Capernaum and Migdal (also known as Magdala), two ancient settlements on the coast of the Sea of Galilee; at Meiron, in the Upper Galilee; and at Gamla, in the western Golan.

The pottery at Capernaum, Migdal and Meiron was dated by its association with datable coins and artifacts and by its location in a dated stratum of remains. By these means, six pottery assemblages from these sites, which were similar to the boat pottery, could be assigned to the period from late first century B.C. to about mid-first century A.D., with one Capernaum assemblage continuing a few decades later. A seventh, similar pottery collection, also from Capernaum, could be dated by three coins in its context to the middle decades of the first century A.D. until about the year 70. One of those coins was from 54 A.D. and two others were from 67–68 A.D.—the former minted at Sepphoris in the 14th year of Nero's reign, and the others from the second year of the Jewish Revolt against Rome. The pottery found at Gamla was all in use before the city was taken by the Romans in 67 A.D., never to be resettled.

By comparing the pottery found near the Galilee boat with these well-dated assemblages from nearby sites, we may conclude that the boat pottery is typical of the period from the late first century B.C. to the decades following the mid-first century A.D., or until about the year 70 A.D. Moreover, later, common Galilean pottery types, first occurring in late first- and early second-century A.D. contexts, are notably absent. The ceramic evidence thus suggests a marked decline or cessation of activity in the vicinity of the boat in the late first century A.D., a conclusion consistent with the Roman victory in 67 A.D. that destroyed the boats of Migdal and left many of its people dead.



## *How Old Is the Galilee Boat?*

By Israel Carmi

---

The Galilee boat has been dated by a method called radiocarbon dating. This method could be used because the boat was made of wood, a carbon-containing material.

To understand radiocarbon dating, it's important to understand some basic facts about the world of nature. Carbon in the atmosphere exists in three forms—called isotopes—that differ in the weight of their atoms but not in their chemical behavior, so organisms use them as if they were exactly the same. The most abundant form is carbon 12, but for every  $10^{12}$  atoms of carbon 12 there is one atom of the heaviest form, radioactive carbon 14. Carbon 14 is constantly being produced in the atmosphere.

To say that carbon 14 is radioactive means that it decays to the stable, non-radioactive nitrogen at a constant rate. This decay accounts for the fact that the number of carbon-14 atoms in the atmosphere and in living organisms, which continuously exchange carbon with the atmosphere as part of the biological processes of life, does not increase without limit but remains approximately constant.

As long as an organism is alive, the carbon within it is composed of the same proportion of carbon 12 and carbon 14 as the carbon in the atmosphere. But when an organism dies, such as a tree cut for use of its wood, the exchange process stops and decay of carbon 14 proceeds without any replenishment of the supply from the atmosphere.

For any particular radioactive isotope, it is possible to measure its half-life, or the time it would take for one-half of the original radioactive atoms in a sample to decay to a stable form. For carbon 14 the half-life is 5,568 years. This half-life makes it useful for archaeology because the changes are large enough for meaningful measurement in the time periods archaeologists care about.

In the case of the Galilee boat, we assume that the wood used to make it was cut within a short time of the boat's construction. Therefore, the radiocarbon age of the wood represents the true age of the boat.

Samples of the Galilee boat's wood, each weighing several grams, were removed and sent to a laboratory. Using gas proportional counters, which count the radioactive decay events that occur within the carbon 14, the amount of radioactive carbon 14 in the sample relative to the amount of stable carbon 12 was measured. Knowing how long it takes for half the atoms of carbon 14 to decay—namely 5,568 years—it was possible to calculate, based on the current proportion of isotopes present, how old the boat was when it was made (that is, when the living trees used for it were cut). Ten samples from different parts of the boat were counted. The result was that the boat began its life as a fishing vessel on the Sea of Galilee in 40 B.C., plus or minus 80 years, or between 120 B.C. and 40 A.D.

## Synagogue Where Jesus Preached Found at Capernaum

By James F. Strange and Hershel Shanks

---

**T**he first-century Capernaum synagogue in which Jesus preached has probably been found. Because more than one synagogue may have existed in Capernaum at this time, we cannot be sure that this new find was Jesus' synagogue. But this recently discovered first-century building is certainly a likely candidate.<sup>a</sup>

At the moment, the synagogue is not a very impressive-looking structure, but it is there nevertheless. And for millions of Christians, that is the important thing. For Jews, too, this find adds important new evidence of how their people worshipped 2,000 years ago. Only a handful of such synagogues are known.<sup>b</sup>



Garo Nalbandian

*Rough black basalt residences of first-century A.D. Capernaum stand in stark contrast to the smooth white limestone of the fourth-century synagogue in the background. Under this synagogue, excavators have found another synagogue made of the same black basalt as the residences in the foreground. The lower synagogue was built on nearly the same plan as the upper limestone synagogue visible here. The walls of the lower synagogue were nearly four feet thick—much thicker than those of these residences—and the walls were made of worked stones, rather than the unworked stones builders used in the residences. The upper synagogue has three entrances on the south, Jerusalem-facing facade. Through these entrances can be seen three rows of columns forming aisles on either side of the prayer hall and the back wall.*

At present, this ancient Capernaum synagogue has been only partly excavated. It may never be fully excavated and exposed because that would require dismantling the beautiful white limestone synagogue built several centuries later on top of the earlier synagogue.

Franciscan archaeologists initially exposed part of the first-century A.D. synagogue in the mid-1960s, but at that time the evidence was not clear enough for them to make the claim of its first-century date. More excavation was needed—this was undertaken in 1981. Now we have the evidence that was lacking.

The synagogue at Capernaum has been known since 1838 when the American orientalist Edward Robinson first explored and identified a number of beautiful architectural fragments in the ruins of Tell Hum, as the site was known locally, as the remains of an ancient synagogue.

Over the years, sporadic excavations exposed parts of the synagogue, but this prompted large-scale looting of the stones by local Arab building contractors. In 1894, the Franciscan Order purchased the site to prevent further depredations and even reburied part of the structure to protect it.

Naturally, much of the interest in Capernaum has stemmed from its importance in Christian history and its frequent mention in the Gospels. Shortly after John the Baptist baptized Jesus in the Jordan River, Jesus settled in Capernaum and made it the center of his ministry until he left for Jerusalem. The Gospel of Matthew (4:13) refers to Capernaum as Jesus' residence.

The Gospels also tell us that Jesus preached and ministered in Capernaum and performed at least one miracle in the synagogue there (see Mark 1:21–25). Understandably, special archaeological attention has been focused on the building that was already identified as a synagogue.

From 1921 to 1926, the Franciscans, under the direction of Fr. Gaudentius Orfali, excavated the synagogue. Orfali dated the synagogue to the early first century A.D. It was, he said, the synagogue in which Jesus had preached. This dating, however, has been universally rejected as far too early.

Although Orfali's dating was wrong, the synagogue he exposed and reconstructed was a jewel. Nestled on the shore of the Sea of Galilee and built of shimmering white limestone on a platform above a town built of rough black basalt boulders, the Capernaum synagogue is the most impressive synagogue unearthed in all of ancient Galilee. Flights of steps on either side of the platform give access to an imposing entrance facade with three doors facing Jerusalem.

Inside the synagogue, along the two long walls, are stone benches, probably to seat the elders who governed the synagogue. The other worshipers sat on mats on the floor, eastern fashion.

Two rows of columns in the main prayer room separate a central nave from two side aisles. In the rear of the main room, a third row of columns creates a third aisle parallel to the back wall. A side room next to the main room served as a school, a court, a hostel for visitors, a dining hall, a meeting place. In antiquity, the synagogue usually included such an auxiliary “community center” room.

Garro Nalbandian



*The interior of the Capernaum synagogue, a large, glistening white limestone structure. Although the synagogue was built in the late Roman style popular in the second and third centuries A.D., Italian archaeologists who excavated the site in 1981 say that the synagogue dates to the Byzantine period—the late fourth or early fifth century A.D.*

*In this photo, taken before 1981, we see the rear or north end of the synagogue—the solid structure at left, 27 feet across. Two rows of columns, perpendicular to the north wall, divide the interior into a central nave and two side aisles—one on the west (foreground) and the other on the east (background). On the left, the row of columns creates a third aisle at the back of the synagogue. In 1981, excavators dug an east-west trench across the nave, revealing a black basalt floor. Both ends of this floor ran up to basalt walls that were directly under the stylobates for the limestone columns that create the two side aisles. (Stylobates are low walls supporting columns.) Pottery found in and under this basalt floor clearly dates the basalt structure to the first century A.D. or earlier. Since the site of a synagogue rarely changed in antiquity, this basalt building, which closely follows the plan of the later limestone synagogue, must also be a synagogue, and very likely the one in which Jesus preached.*

In 1968, the Franciscans renewed their excavations in the synagogue under the direction of two Franciscan fathers, Virgilio Corbo and Stanislao Loffreda.

These excavations touched off one of the most spirited debates in archaeological history—concerning the date of this beautiful ancient synagogue. On one point, all were agreed, however. This synagogue could not be the first-century synagogue in which Jesus preached. Israeli scholars contended that the building dated to the late second or third century A.D. The Italian excavators, however, contended that the building dated to the late fourth or early fifth century A.D.

The debate is fascinating because it involves archaeological, historical and architectural evidence—and each side seems to have a convincing case!

The Italians rely primarily on a hoard of more than 10,000 bronze coins they found under the pavement of the present synagogue building. As we have already noted, the present synagogue building was constructed on a platform created by the use of fill in order to give the structure a more monumental appearance. According to the Italians, a thick layer of mortar was laid on top of this fill, and the

synagogue pavement was laid on top of the mortar. The Italian excavators found their coins in the fill and in the mortar which, they claim, sealed the fill below it. Some of the coins were actually embedded in the mortar. These coins have been dated to the fourth and fifth centuries and, according to the Italians, require them to date the synagogue building to the same period.

The Israelis, on the other hand, emphasize the artistic and stylistic parallels to the Capernaum building that clearly point to the end of the second or third century for its construction. That is when 20 or so stylistically similar synagogues were built in the Galilee and on the nearby Golan Heights. Moreover, this late Roman style is entirely different from the Byzantine synagogues with mosaic floors built in the late fourth and fifth centuries, sometimes within miles of the Capernaum synagogue. One such synagogue from the Byzantine period is at Hammath-Tiberias, only ten miles from Capernaum. As one Israeli scholar remarked, were these buildings in fact contemporaneous, “We would probably find this to be the only case of such astounding architectural diversity within so small an area.”

Even more important to the Israelis’ argument is the fact that barely 30 feet from the Capernaum synagogue, the Italian excavators found a relatively modest fourth-century church built over St. Peter’s House (see “Has the House Where Jesus Stayed in Capernaum Been Found?” **BAR** 08:06). It is surely unlikely, argue the Israelis, that so magnificent and richly decorated a synagogue as Capernaum’s would be allowed to be built so close to a church whose religion was now the state religion. As one Israeli scholar has commented, “Such a state of affairs might be conceivable in our ecumenical age, but it seems impossible to imagine that it would have been allowed by the Byzantine authorities of the fourth century.” No doubt there were synagogues built in the fourth century (probably by bribing local officials, because Byzantine law at the time forbade the erection of new synagogues), but all their splendor was reserved for the interior, not flaunted on the exterior, as was the case at Capernaum. To build a fourth-century synagogue so beautifully adorned on the outside—including the use of explicit Jewish symbols like the menorah, shofar, incense shovel, date palms (which symbolize Judea), lulav (the palm branch used during the Jewish festival of Tabernacles), and a representation of the paneled doors of the ark—would only emphasize the violation of the emperor’s law forbidding the construction of synagogues.

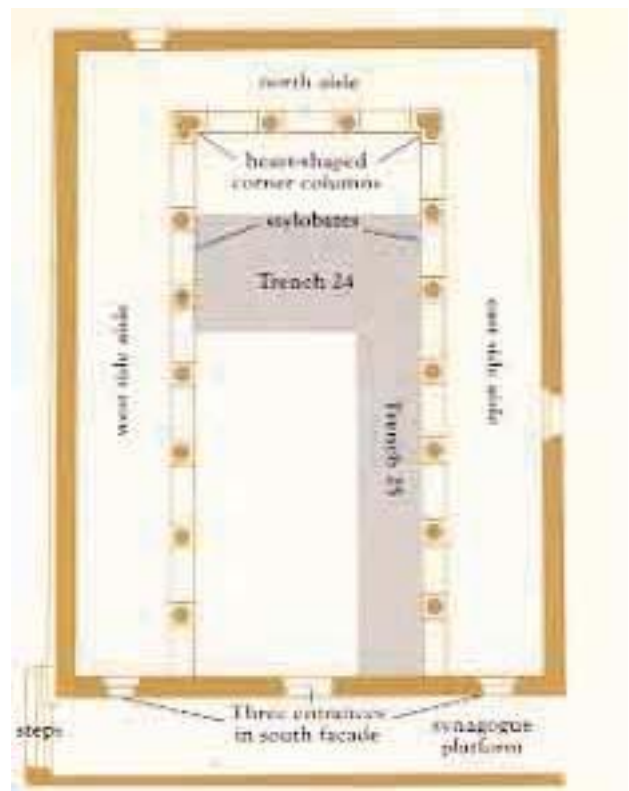

Adapted from *Studia Hierosolymitana III* (Virgilio Corbo)

*Prayer room of fourth- or fifth-century limestone synagogue at Capernaum.*

For all these reasons, most Israeli scholars adhere to the second- to third-century dating for the Galilean basilica-plan synagogues, including Capernaum.

But what of the coins “hermetically sealed,” as the Italian excavators put it, under the synagogue pavement? How did these coins dating from the fourth and fifth centuries get under the floor of a second- or third-century building? Perhaps, say the Israelis, the pavement was re-laid in the fourth century, at which time a fill could have been spread inside the building and a layer of mortar placed over it.

The outcome of this debate is still uncertain. If the Italians prove correct, it may require scholars to rewrite the history of the Jews in Palestine during the fourth and fifth centuries A.D. As we know the period today, it was one of persecution and decay, a time when Jews emigrated from the Holy Land instead of coming to it. A fourth- or fifth-century dating of the Capernaum synagogue would indicate that this was a period of prosperity and vigor, a time when Jewish life flourished.

In the midst of this debate a minor point in the Franciscan excavations went almost unnoticed—almost, but not quite.

In the course of their excavation, the Franciscans uncovered what seemed to be part of a wall under the limestone wall of the synagogue. This lower wall was built of worked black basalt blocks, without mortar. This same black basalt was used to construct the residential buildings that surrounded the synagogue, including the building the excavators identified as the first-century house of St. Peter.

In his preliminary report on the synagogue excavation, published in 1975, Corbo described this lower wall as a “foundation” of the south wall of the white limestone synagogue. In Italian, this lower basalt wall is called *muro di basalto*, Wall of Basalt. Corbo therefore labeled it “MB” in his notes—so this is what we shall sometimes call it and the similar walls related to it.

The excavators turned up this wall, or walls very much like it, in no fewer than six of their trenches. It stood to a height of about three feet. They found it beneath all four corners of the limestone synagogue in addition to the section they found beneath the south wall.

Then Corbo exposed this basalt wall for a length of 24 meters (78 feet) along the west wall of the synagogue—the entire length of the west wall of the synagogue.

There was something puzzling, however, about this black basalt wall that served as the foundation wall of the white limestone synagogue. At the southwest corner of the synagogue where the basalt wall appeared most clearly, it was out of alignment with the wall of the synagogue that rested on top of it. The MB or basalt wall extended almost a foot west of the southwest corner of the limestone synagogue wall. Why was this supposed foundation wall so clearly out of orientation with the wall it supposedly supported?

Corbo, ever the cautious scholar, refused to speculate. But in fact both Corbo and Loffreda suspected at a quite early stage that the MB or basalt wall may have been the wall of an earlier building, which was later used as a foundation wall for the limestone synagogue. The earlier building may itself have been a synagogue, perhaps from the first century A.D. More evidence was needed, however.

Even without additional evidence, a prominent Israeli scholar, Michael Avi-Yonah of Hebrew University in Jerusalem, suggested as early as 1967 that the MB (*muro di basalto*) might be the wall of an earlier synagogue.

Additional evidence was uncovered in excavations conducted by Corbo and Loffreda in 1981. The results have now been published in Italian.<sup>c</sup>

In the nave of the limestone synagogue, in the large central area between the two long rows of columns, two long excavation trenches were sunk in 1981 for the purpose of tracing the basalt wall beneath the limestone synagogue. Corbo's first trench (trench 24) ran east-west across the nave. Originally, this area had been paved with limestone pavers used in the limestone synagogue. Beneath the pavers was a layer of mortar that still bore the imprint of the limestone pavers. Then the excavators slowly chipped away at a foot of mortar.

Below the mortar was a thin layer of limestone chips. These were the cuttings or debris left by the workers who cut the blocks for the limestone synagogue's walls.

Beneath this thin layer was a fill more than three feet deep consisting of hammer-dressed basalt boulders mixed with dirt. This was the fill set in place by the builders of the limestone synagogue to create the platform on which the limestone synagogue was erected.

Adapted from *Studia Hierosolymitana III* (Virgilio Corbo)



Nearly four feet below the surface, under the fill, the excavators hit a patch of rude cobbled pavement of black basalt. This patch was only ten feet long. On the patch of cobbled pavement were potsherds from the first to the fourth centuries A.D. The first-century pottery fixes the earliest date when the patch of cobbled pavement under the potsherds could have been laid.

*Trench 24: (1) eastern stylobate (4th–5th century synagogue); (2) pavement (4th 5th century synagogue); (3) basalt wall (MB) (1st century synagogue); (4) basalt pavement (1st century synagogue).*

At a point more than four feet below the nave of the limestone synagogue, the excavators found a pavement of basalt cobbles that extended throughout the entire length of the trench. Obviously, here was the floor of an earlier building. The pottery found in and under this cobbled floor dates to the first century A.D. or earlier. Loffreda published this pottery in extensive groups, and it clearly establishes a first-century A.D. date for the cobbled basalt floor.

At the end of the trench, the cobbled pavement ran up to black basalt walls that, Corbo immediately recognized, were identical to the black basalt walls he had found earlier.

The new basalt walls also appeared beneath the limestone synagogue's stylobates. A stylobate is a special support wall for a row of columns necessitated by the additional load the columns bear. In the limestone synagogue there are rows of columns on three sides of the nave, creating two side aisles and a back aisle. Each row of columns has its own stylobate. The newly discovered basalt walls that the cobbled floor abutted were under the stylobates for the columns that created the side aisles in the limestone synagogue. These basalt walls served as foundation walls for the limestone stylobates. Originally, however, they were part of an earlier building.

The Italian excavators then opened another trench (trench 25) in the nave beside the eastern, limestone stylobate, extending for the stylobate's entire length. The same stratigraphy (or layers) was found in this trench. The archaeologists found that the basalt wall ran almost the entire length of the eastern stylobate, serving as its foundation. This wall matched traces of the basalt wall found beneath the western stylobate.

It is now clear that the basalt walls beneath the limestone synagogue walls are the walls of an earlier building. True, they now serve as foundation walls for the stylobates and walls of the limestone synagogue. But they were not built as foundations. They were built as walls and stylobates of an earlier building and then reused as foundation walls by the builders of the limestone synagogue. This is the explanation for the fact that one of the basalt walls, as we pointed out earlier, is not in proper alignment with the limestone wall above it.

The consistent structure of the basalt walls (hammer-dressed boulders of uniform size, without mortar) in all the various places they have been found confirms that they all belonged to an earlier building.

There is another reason for this conclusion. As noted, beside the prayer room of the limestone synagogue is a colonnaded room that was probably used as a kind of community center. The entrance to this room is through the east wall of the synagogue's main prayer room. Beneath this side room the excavators did not find any of the basalt walls they found under the prayer room. If the basalt walls had been built as foundation walls for the limestone synagogue, we would expect to find them under this side room of the limestone synagogue as well. The absence of basalt walls suggests that the walls under the prayer room, which were later used as foundation walls for the limestone synagogue, belonged originally to a structure that did not extend under the room beside the prayer room.



Another reason to conclude that the basalt walls were the walls of an earlier building stems from the treatment of odd gaps in the basalt walls. For example, there is a nearly five-foot gap in the basalt wall beneath the southern end of the eastern stylobate. The builders of the limestone synagogue needed a foundation here as well as under the rest of the stylobate, so they erected a column of mortar and stone on top of the remains of a floor at the bottom of the gap. In this way they provided support for the southern end of the eastern stylobate.

We can also conclude that this earlier building was not a private house but was, rather, a public building. This is clear from the fact that the basalt walls are nearly four feet thick. Only public buildings have such thick walls. Indeed, the walls of the limestone synagogue are only about 2.5 feet thick.

Moreover, with the additional material from the latest excavations, the plan of the earlier building has emerged with considerable clarity. It appears to follow quite closely the plan of the prayer hall of the limestone synagogue. The walls of the earlier building appear everywhere under the walls of the later building. Basalt walls were also found under the stylobates of the later building. In trench 25, which parallels the eastern stylobate, the excavators were able to follow the basalt wall under the eastern stylobate for a very considerable length. They found that this basalt wall did not extend

all the way to the north or south wall of the limestone synagogue. In other words, the basalt wall under the stylobate stopped about where the stylobate of the limestone synagogue stops. This indicates that the basalt wall was, so to speak, freestanding in the earlier building, and may have been used to support an earlier stylobate, rather than enclosing a side room.

As shown in the drawing, based on parallels from other first-century synagogues, the excavators even assume that benches lined the side aisles of the basalt building.

No entrance to the earlier building has been located. However, there is a clear break in the basalt wall on the west side of the building between and beneath the second and third pilasters of the limestone synagogue wall; a door may once have been located here. Such an entrance is also suggested by the plan of a recently excavated synagogue at Magdala which is a parallel to the building we are examining, although much smaller. (The excavators call it a mini-synagogue.<sup>1</sup>)

Adapted from *Studia Hierosolymitana III* (Virgilio Corbo)

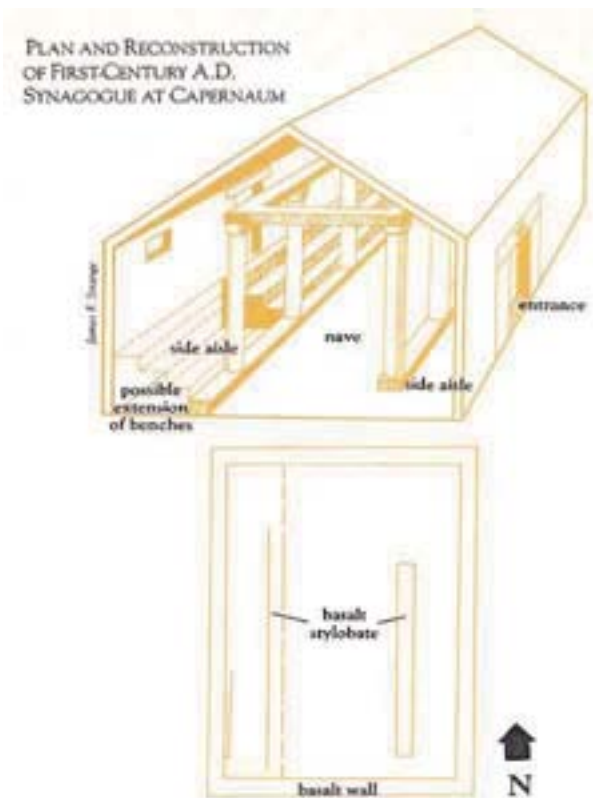

Plan and reconstruction of first-century A.D. synagogue at Capernaum.

The Magdala plan also tends to confirm the accuracy of our reconstruction of the plan of the earlier building at Capernaum.

The date of this earlier building with basalt walls and a cobbled floor also seems clear. The pottery under the cobbled pavement dates from the third century B.C. to the latter half of the second century B.C. One of the coins found under the cobbled pavement was a coin of Ptolemy VIII Eugertes, who reigned from 146 B.C. to 117 B.C., although the coin may well have continued in circulation for some period after his death. On and in the cobbled pavement, the excavators found pottery sherds dating from the first century A.D. to the fourth century A.D.<sup>2</sup> The floor was doubtless founded in the first century at the latest, and the basalt walls are clearly associated with this floor.

But is the earlier building a synagogue? The answer is yes, for several reasons.

Synagogues, and holy places in general, commonly remain in the same location. A new synagogue is customarily built over the remains of an old one. We know this from numerous excavations. Synagogue locations simply did not move around within an ancient town.

A famous pilgrim named Egeria traveled through Palestine from 381 to 384 A.D. and visited Capernaum at that time (see review of *Egeria's Travels to the Holy Land*, Books in Brief, **BAR** 09:02). Peter the Deacon, writing in 1137 A.D., quotes from a copy of Egeria's *Travels* no longer extant, except as quoted by Peter: "In Capernaum the house of the prince of the apostles [Peter] has been made into a church, with its original walls still standing. It is where the Lord healed the paralytic. There is also the synagogue where the Lord cured a man possessed by the devil [Mark 1:23]. The way in is up many stairs, and it is made of dressed stone" (V1.2). The Franciscan excavator Corbo believes Egeria was referring to the later, white limestone synagogue. Nevertheless, she attests to an ancient tradition even then that this was the site of the synagogue in which Jesus cured the demoniac.

The similarity of the plan of the earlier building to other ancient synagogues of the period also suggests that this earlier building was a synagogue. The plan of the earlier building is similar to the plan of synagogues found at Masada, Herodium, Gamla and Magdala, although, as the accompanying table shows, the earlier building at Capernaum was the largest of them—an indication of its importance.

Architectural fragments that were probably used in the earlier building at Capernaum were found in the fill of the platform created for the limestone synagogue. These fragments are surely consistent with the identification of the building as a synagogue, even if they do not prove it. In the fill below the mortar of the later synagogue, the excavators found impressive column drums—one in beautiful gray granite—and fragments of two kinds of elegant cornice molding. All these fragments probably came from the earlier building and were reused as part of the fill creating the platform for the later building.

**Comparison of External Dimensions of Early Synagogues**

Synagogue	Width m/ft	Length m/ft	Area sq. m/sq. ft.	% of Capernaum area
Capernaum 1st Century	18.5/60.7	24.2/79.4	448/4838	100
Magdala	7.3/23.9	8.1/26.5	59/637	13
Gamla	15.4/50.5	19.4/63.6	299/3229	67
Masada	12.8/42.0	16.3/53.5	209/2257	47
Herodium	12.3/40.3	16.7/54.8	205/2214	46

Adapted from Liber Annuus 24 (1974)

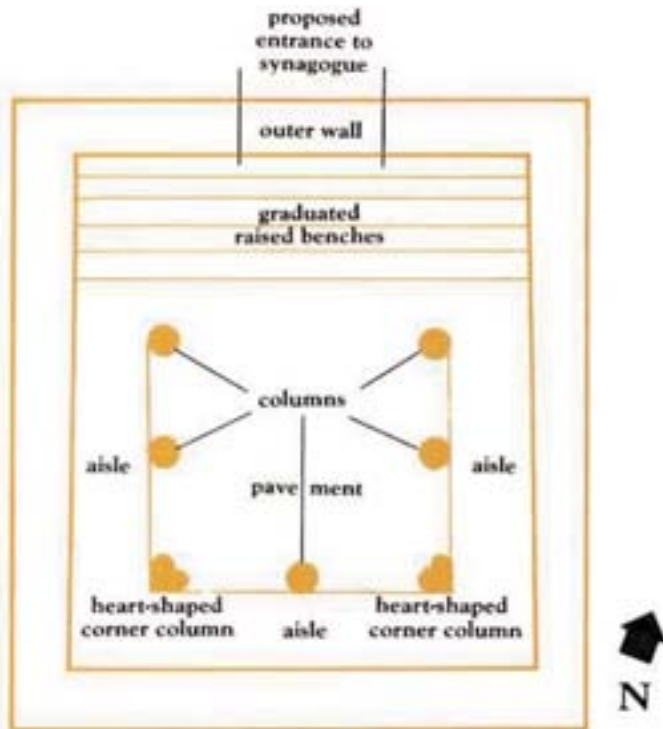

*Plan of Magdala synagogue.*

The conclusion that this was a first-century A.D. synagogue seems inescapable.

Corbo has concluded that this earlier building was the first-century synagogue in which Jesus preached. Luke 7:15 recalls certain Jewish elders from Capernaum who tell Jesus of a Roman centurion who “... loves our nation, and built us our synagogue.” In his recent Italian publication, Father Corbo concludes: “This edifice, after thirteen years of patient labor of excavation and of recording, has been found appropriately under the area of the synagogue of the fourth/fifth centuries. We think therefore with all legitimacy that the edifice of basalt walls excavated under the synagogue is properly the synagogue constructed in the first decades of the first century by that Roman centurion of whom Jesus said, ‘Truly I say to you, neither in Israel have I found such faith’ (Luke 7:9).”

## Notes

- a. The Gospels always speak of “the” Capernaum synagogue. Perhaps this was because there was one synagogue in Capernaum or the Gospel writers knew of only one synagogue. But it is also possible they said “the” because all their attention was focused on this synagogue.
  - b. Other first-century synagogues are known from Masada, Herodium, Gamla (probably), Magdala and perhaps Chorazim. In addition, an inscription from such a synagogue has been found in Jerusalem (see Hershel Shanks, *Judaism in Stone*, **Biblical Archaeology Society** and Harper and Row: New York and Washington, 1979, pp. 17–19).
  - c. Stanislao Loffreda, “Ceramica Ellenistico-Romana nel Sottosuolo della Sinagoga di Cafarnao,” and Virgilio C. Corbo, “Restidella Sinagoga del Primo Secolo a Cafarnao,” in *Studia Hierosolymitana* III (1982), pp. 273–357.
1. Virgilio Corbo, “La Citta romana di Magdala,” *Studia Hierosolymitana* I, pp. 365–368.
  2. Vigorous discussion in archaeological journals occurred when the Franciscan fathers Corbo and Loffreda first published their proposal for a fourth-century date for the white limestone synagogue at Capernaum (see Virgilio Corbo, Stanislao Loffreda, Augusto Spijkerman, *La Sinagoga di Cafarnao dopo gli scavi del 1969*, Franciscan Printing Press: Jerusalem, 1970). The announcement that fourth-century sherds were found on a first-century floor under four feet of fill and mortar is sure to generate even more debate.

## Has the House Where Jesus Stayed in Capernaum Been Found?

Italian archaeologists believe  
they have uncovered St. Peter's home

By James F. Strange and Hershel Shanks

---

Italian archaeologists claim to have discovered the house where Jesus stayed in Capernaum. Proof positive is still lacking and may never be found, but all signs point to the likelihood that the house of St. Peter where Jesus stayed, near Capernaum's famous synagogue, is an authentic relic.

Nestled on the northwest shore of the Sea of Galilee, the ruins of Capernaum slumbered peacefully for hundreds of years; indeed, some of its remains went undisturbed for thousands of years. Modern investigation of this site began in the mid-19th century, but even now the earth is still yielding new secrets. What the future holds, no one knows.

An American explorer and orientalist, Edward Robinson, first surveyed the site in 1838. Robinson correctly identified some exposed architectural remains as an ancient synagogue, but he did not connect the site with ancient Capernaum.

In 1866, Captain Charles Wilson conducted limited excavations on behalf of the London-based Palestine Exploration Fund. Wilson correctly identified the site as Capernaum and concluded that the synagogue was the one referred to in Luke 7:5, which was built by a Roman centurion who had admired the Jews of Kfar Nahum (Capernaum<sup>a</sup>).

As a result of the British interest in the site, local Bedouin began their own search for treasure. They smashed and overturned ancient architectural members looking for small finds to sell on the local antiquities markets. The Bedouin were soon followed by local Arab contractors who appropriated overturned and broken stones for use in new construction projects.

At last in 1894, the Franciscan Fathers acquired the site in order to protect its precious remains. To ensure that the exposed remains would not be carried away, the Franciscans reburied some of them and built a high stone wall around the property.

Garo Nalbandian, courtesy Fr. Virgilio Corbo



*The Capernaum synagogue, residential area and octagonal church, clustered on the northwest shore of the Sea of Galilee. Beyond the trees is the red brick convent of the Franciscan Fathers.*

*The synagogue was built on a platform, mounted by steps at its southeast and southwest corners; the southwest steps are visible in this photo. The steps lead to a courtyard, or room, with an intact flagstone floor. This auxiliary room probably served as the synagogue's school room. The interior of the main prayer room was divided by two parallel rows of columns forming a nave and two aisles.*

*Recent excavations uncovered more ancient buildings beneath this synagogue. Since we know that, historically, the site of a town's synagogue rarely changes, one of these earlier buildings was very likely the Capernaum synagogue in which Jesus preached.*

*South of the synagogue is a residential area, the remains of private homes. Beyond that (84 feet south of the synagogue) is the octagonal church built over St. Peter's house.*

Naturally, special Christian interest in the site stemmed from Capernaum's importance in Jesus's life and ministry. According to the Gospel of Matthew, Jesus left Nazareth and "settled" in Capernaum (to render the verb literally) (Matthew 4:13). In and around Capernaum Jesus recruited several of his disciples including Peter, who was to become his spiritual fisherman (Mark 1:16–20). Jesus performed a number of miracles in Capernaum—for example, curing the man with the withered hand (Mark 3:1–5). Jesus frequently preached and taught at the Capernaum synagogue (Mark 1:21). In the Capernaum synagogue, Jesus first uttered those mystical words:

"Whoever eats my flesh and drinks my blood possesses eternal life, and I will raise him up on the last day ... As the living Father sent me ... he who eats shall live because of me. This is the bread which came down from heaven." (John 6:54–58)

The word of Jesus went forth first from Capernaum. Capernaum was not only the center of Jesus's Galilean ministry, but it was also the place of his longest residence.

Where did Jesus live in Capernaum? While we are not told specifically, the fair inference seems to be that he lived at Peter's house. We are told that Jesus "entered Peter's house, [and] saw his mother-in-law lying sick with a fever..." (Matthew 8:14). That evening

he was still at Peter's house (Matthew 8:16). Apparently Jesus lived there. In Mark we read that "when he [Jesus] returned to Capernaum after a few days, someone reported that he was at home" (Mark 2:1). The home referred to, it seems, is Peter's house. This same passage from Mark speaks of four men digging through the roof of the house to lower a paralytic on a pallet so that Jesus could heal him:

"And when he returned to Capernaum after a few days, someone reported that he was at home. And many were gathered, so many that they did not have any room, even about the door. And he was speaking the word to them. And they came bringing to him a paralytic, carried by four men. And since they could not get to him because of the crowd, they took apart the roof where he was. And when they had dug out a hole, they lowered the pallet on which the paralytic lay.

And when Jesus saw their faith, he said, 'My son, your sins are forgiven.' (Mark 2:1–5). See "Arise, Take up Thy Bed and Walk," a late Renaissance painting of this Bible scene by the Flemish artist, Jan van Hemessen, in Books in Brief, in this issue.

Until 1968, the primary focus of excavations at Capernaum was the synagogue. This is understandable. It is indeed a magnificent building of shimmering white limestone that stands out in stark contrast to the rough black basalt of the surrounding houses. The synagogue was constructed on a platform to conform with the rabbinic injunction to build the synagogue on the highest point in the town.<sup>b</sup> The synagogue is entered by a flight of steps on either side of the platform. The entrance facade contains three doors facing Jerusalem.

Inside the synagogue, two rows of stone benches, probably for elders who governed the synagogue, line the two long walls. The other congregants sat eastern fashion on mats on the floor.

Two rows of columns divide the main prayer room into a central nave and two side aisles. Parallel to the back wall, a third row of columns creates a third aisle in the rear of the main room. Adjoining the main room was a side room that was no doubt used for a variety of community functions—as a school, a court, a hostel for visitors, a dining hall, a meeting place. In antiquity, the synagogue served all these functions.



Garo Nalbandian

*The interior of the Capernaum synagogue. Although this impressive row of white limestone columns looks like a facade, it is actually the narrow north end of the synagogue nave, 27 feet across. On either side of the nave, parallel to its length, is an aisle formed by rows of columns. The intact column in the left foreground and the broken one in the right foreground are two of the columns that separated the nave from the west aisle. The broken column in the rear of the photo is on the east aisle. The columns rest on pedestals, each carved from one stone. Originally, a second story of columns above the aisle ceilings formed an open gallery or balcony overlooking the nave. In the aerial photograph one may clearly see the nave with its two flanking side aisles perpendicular to the row of standing columns.*

Garo Nalbandian



A Corinthian column capital from the Capernaum synagogue. A seven-branched candelabrum (menorah) decorates this elaborately carved capital. To the right of the menorah's base is a ram's horn (shofar) and, to the left, an incense shovel; both are ritual objects once used in the Temple in Jerusalem. This capital may have stood atop one of the columns separating the nave from an aisle inside the synagogue.

When this synagogue was first excavated by the Franciscan Friar Gaudentius Orfali in the 1920s, Friar Orfali identified it as the synagogue in which Jesus had preached and performed miracles. Today, however, all competent scholars reject this dating of the Capernaum synagogue. In 1968, the Franciscans renewed their excavations in the synagogue under the direction of two Franciscan fathers, Virgilio Corbo and Stanislao Loffreda. This pair of Italian scholars concluded that the synagogue dated to the

fourth or fifth century A.D. Their dating was based primarily on a hoard of 10,000 coins they found under the synagogue floor. This new conclusion set off a lively debate, still unresolved, among scholars who had previously contended that the building should be dated to the late second or third century A.D.

Garo Nalbandian



Whatever the date of the surviving Capernaum synagogue, it is likely that the Capernaum synagogue in which Jesus preached stood on this same spot—although this cannot be proved. As we know from other communities, synagogue

*Black basalt walls remain from houses at Capernaum in which Peter's contemporaries may have lived. The rough black basalt contrasts strikingly with the synagogue's finished white limestone. The synagogue was built on a platform—which runs to the end of the photo at right—in order to conform to the rabbinic injunction (Tosephta. Megillah IV 23) to erect the synagogue at the town's highest point.*

*The construction of the basalt houses is identical to that of the house of St. Peter found beneath the octagonal church. Small stones were pounded between the large ones to strengthen the walls, but no mortar was used. The floors were also made of these rough basalt stones, often obtained from nearby wadis.*



sites rarely change within a town. A new synagogue is simply reconstructed on the site of the old one. Recently, traces of earlier buildings have been found below the extant Capernaum synagogue. Judging from the size of these earlier buildings and the paving on their floors, they were probably private homes. One of these earlier remains may well be of a home converted into a synagogue in which Jesus preached.

The excavations undertaken by the Franciscans beginning in 1968 went far beyond the synagogue, however. The Franciscans also worked to uncover the town of which the synagogue was a part. It was in this connection that they discovered what was probably St. Peter's house where Jesus stayed when he lived in Capernaum.

Indeed, it was while investigating the context of the synagogue that they became especially interested in the remains of an unusual octagonal-shaped building 84 feet south of the synagogue, opposite the synagogue facade facing Jerusalem. This octagonal building had long been known and, along with the synagogue, it was frequently mentioned in medieval travelers' accounts.

Friar Orfali had done some work on the octagonal building in the 1920s. His plan showed the building as consisting of three concentric octagons. He found only four sides of the largest octagon, which was about 75 feet across; he assumed the other sides had been replaced by later construction. The second octagon was about 57 feet across; and the smallest 26 feet. The smallest octagon had rested on eight square pillars crowned by arches to hold the roof. The building had been paved with mosaics, traces of which remained. Inside the smallest octagon was an octagonal mosaic band of lotus flowers in the form of a chalice; in the center of this mosaic was a beautiful peacock, an early Christian symbol of immortality. Unfortunately, the head and feet of the peacock had been destroyed.

Opinion regarding the octagonal building varied. Local guides invariably pointed it out to gullible tourists as the house of St. Peter, although its identification even as a private residence was not accepted by most scholars. Some suggested the concentric octagons were the public fountains of ancient Capernaum. The best scholarly view, however, was that it was an ancient church. Friar Orfali identified the building as a Byzantine baptistry, citing similar octagonal structures in Europe, such as San Giovanni in Fonte of Ravenna.

When Corbo and Loffreda renewed excavations in 1968, they discovered an apse together with a baptistry on the east side of the middle octagon—which was why the third or outer octagon did not close. The building was oriented by the apse to the east, the orientation of most ancient churches. The discovery of the eastward-oriented apse and the baptistry removed any doubt that the structure was in fact an ancient church. The Franciscans dated it to the middle of the fifth century A.D. In its first phase, the church consisted of but two concentric octagons. The outer partial octagon was added later to form a portico on five of the eight sides—on the north, west, and south. The other three sides were occupied with the apse and two sacristies<sup>c</sup> on either side of the apse. The precise date of these additions has not been determined.

## The Galilee Jesus Knew

Plan adapted from Cafarnao I: Gli Edifici Della Citta (Franciscan Printing Press: 1975)

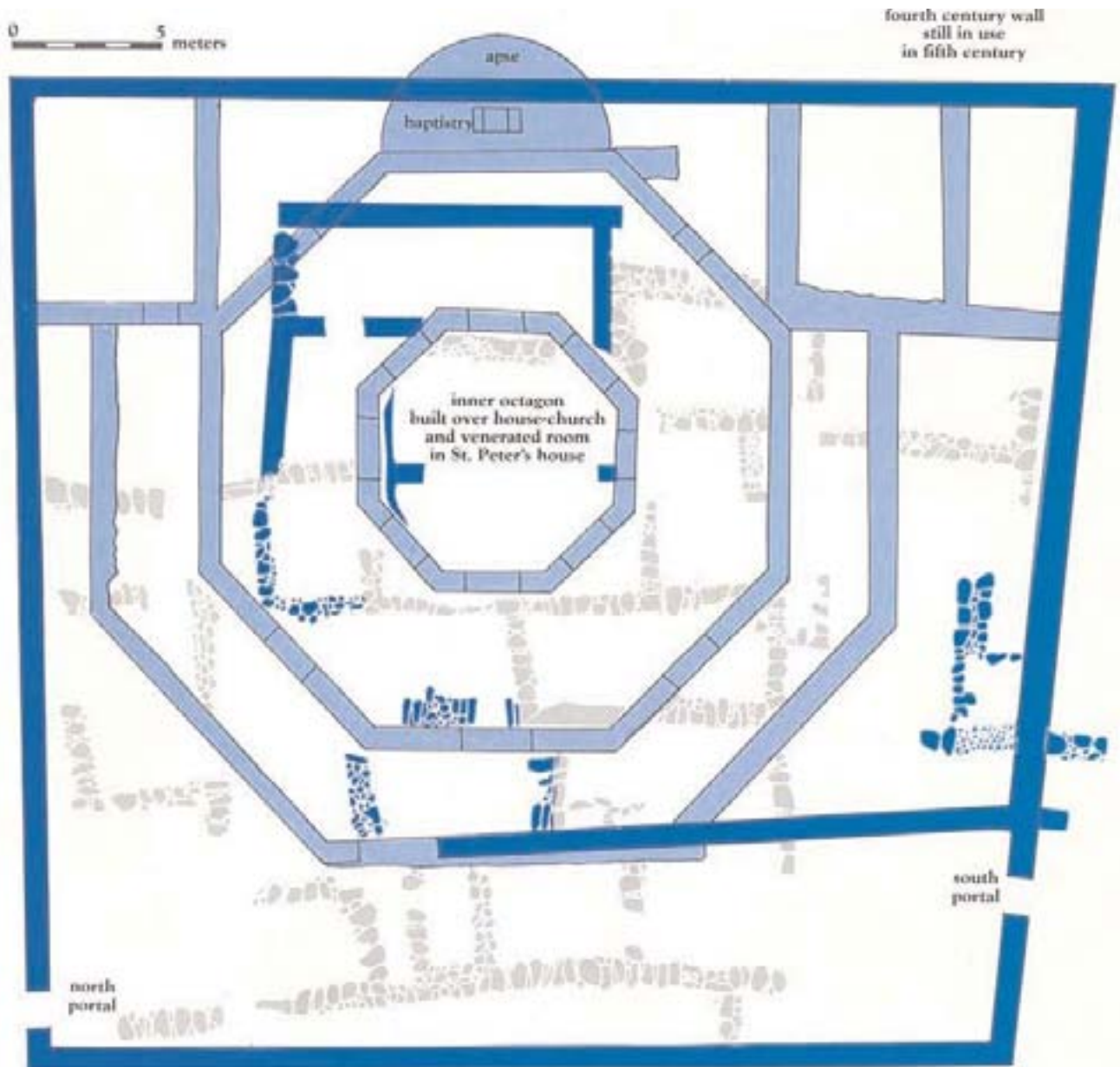

*The octagonal church (5th century A.D.), superimposed on 4th and 1st century remains.*

But why was the church built in the shape of an octagon? The answer is that octagonal churches were built to commemorate special events in Christian history which supposedly occurred at the site. For example, the Church of the Nativity in Bethlehem was built in an octagonal form by the Emperor Constantine in the fourth century A.D., supposedly directly over the cave where Jesus was born. The octagon in the Bethlehem church was intended to mark this spot. Presumably the octagonal church at Capernaum was intended to mark some other site of special importance in Christian history.

It is reasonable to assume, therefore, that this octagonal church at Capernaum was a memorial church. Some scholars believed that the octagonal church was built to memorialize Jesus's temporary residence in Capernaum and may well have been connected with ancient memories or traditions regarding the location of St. Peter's house, also called "the house of Simon and Andrew" in Mark 1:29.

When the Franciscan archaeologists, in their renewed excavations, dug beneath the mosaic floor of the church they found some hard evidence to support this speculation.

Directly beneath the octagonal church they found the remains of another building which was almost certainly a church, judging from the graffiti on the walls left by Christian pilgrims. For example, a graffito scratched on one wall reads, "Lord Jesus Christ help thy servant ... " A proper name followed in the original but is no longer readable. Another graffito reads, "Christ have mercy." Elsewhere on the walls crosses are depicted. The graffiti are predominantly in Greek, but some are also in Syriac and Hebrew. The presence of Hebrew graffiti suggests that the community may have been composed of Jewish-Christians at this time.

The central hall of this lower church is 27 feet long and 25 feet wide. The roof was supported by a large two-story-high arch over the center of the room. Two masonry piers made of worked basalt blocks, found against the north and south walls of the room, supported the arch. In addition to the bases of the piers, the excavators found two voussoirs, or wedge-shaped stones, from the arch that once supported the roof. The voussoirs were still covered with plaster and paint.

Two doors on the south and one on the north allowed easy access to the central hall. Smaller rooms (9 feet × 12 feet) adjoined the hall on the north. A long narrow room (10 feet × 27 feet) on the east is called the atrium by the excavators. Outside the atrium,

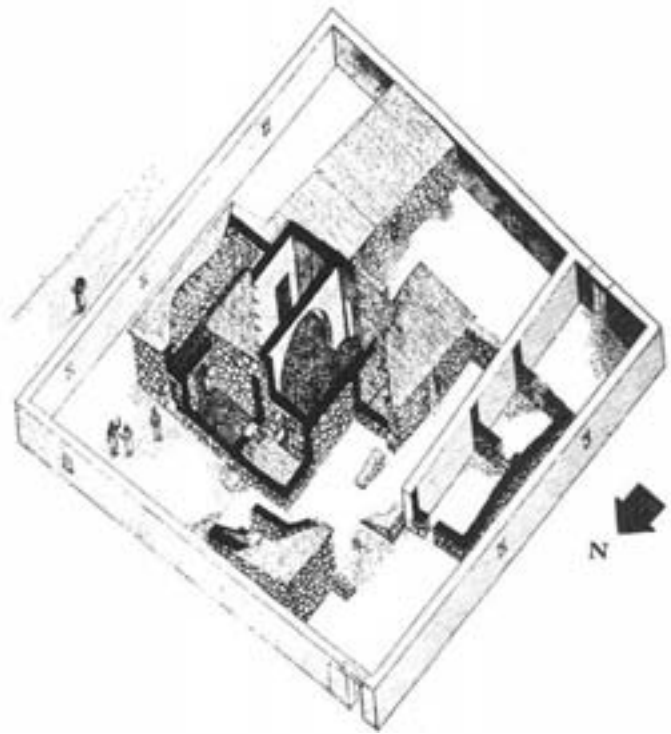

Museum of the Studium Biblicum Franciscanum

*House-church from the fourth century. In this artist's reconstruction, we can see that the main room of St. Peter's first century house has been renovated. Entrances have been added and an arch built over the center of the room supports a two story high masonry roof. The original black basalt walls remain but they have been plastered, the room is now the central hall of a church. On the east side of this now venerated room is an atrium, or entryway, 10 feet wide and 27 feet long. Surrounding the house-church compound is a wall about 88 feet square.*

which probably served as an entryway into the central hall, is a thoroughfare paved with hard-packed beaten earth and lime, providing a good solid surface for heavy foot traffic.

The central hall was plastered all over and then painted in reds, yellows, greens, blues, browns, white and black, with pomegranates, flowers, figs and geometric designs. Other objects almost surely appeared, but the fragmentary nature of the plaster makes

Plan adapted from Cafarnao I: Gli Edifici Della Citta (Franciscan Printing Press: 1975)

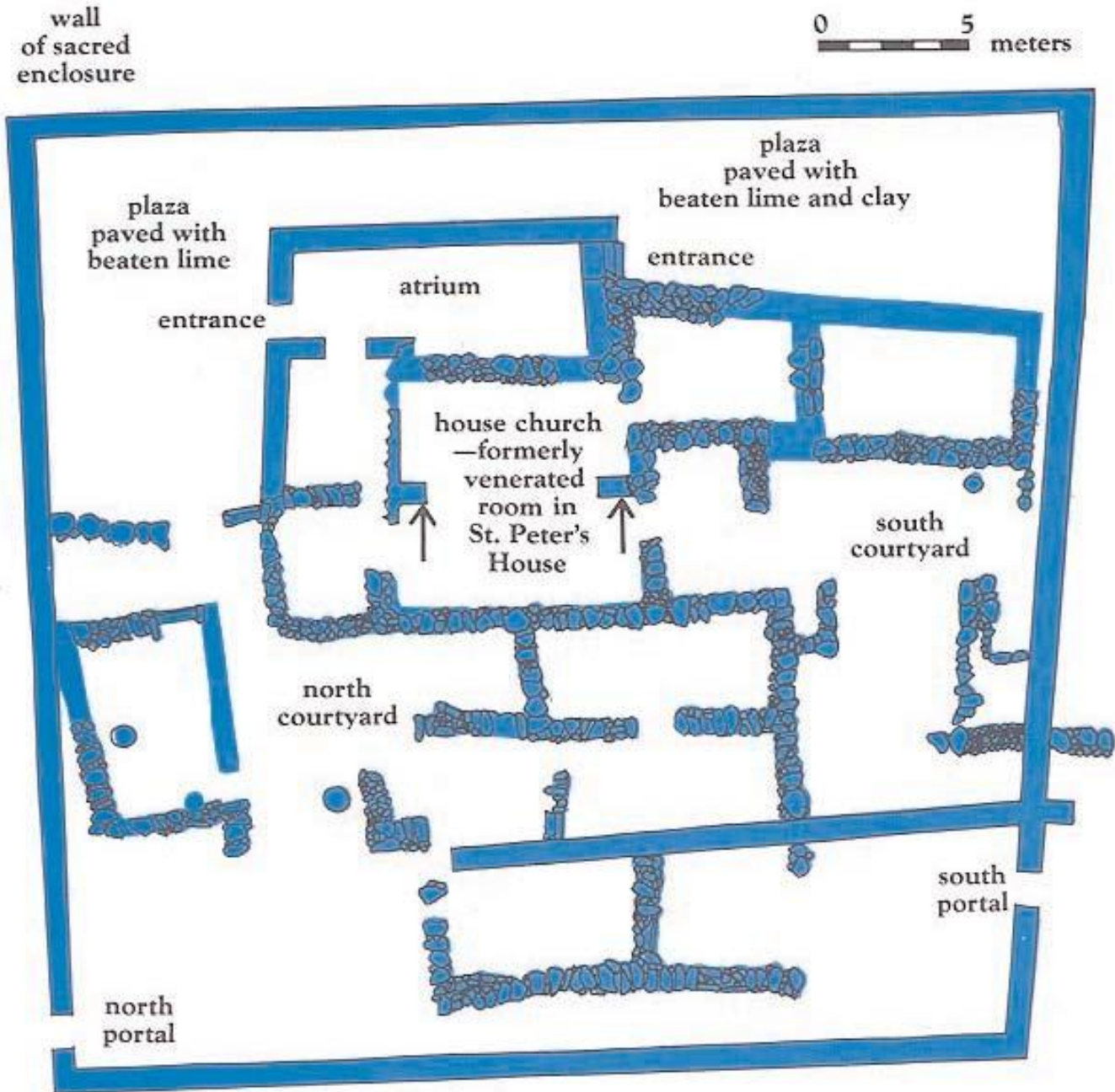

The house-church (4th century A.D.).

interpretation difficult. The entire church complex was surrounded by a wall about 88 feet long on each of its four sides.

This church complex we have just described was its final phase only, just before the octagonal church was built directly above it. This was how it existed in the late fourth century. However, the origins of this fourth century church are of a far earlier time.

According to the excavators, the central hall of this church was originally built as part of a house about the beginning of the Early Roman period, around 63 B.C. Not all

the house has been excavated, but almost 100 feet north to south and almost 75 feet east and west have been uncovered. This house was originally built of large, rounded wadi stones of the rough black basalt that abounds in the area. Only the stones of the thresholds and jambs of the doors had been worked or dressed. Smaller stones were pounded between the larger ones to make the wall more secure, but no mortar was used in the original house. Walls so constructed could not have held a second story, nor could the original roof have been masonry; no doubt it was made from beams and branches of trees covered with a mixture of earth and straw. (This is consistent with the tale of the paralytic let down through a hole in the roof). The archway was probably built inside the central room of the house in order to support a high roof when the house was later converted to a church.

The original pavement of the room also consisted of unworked black basalt stones with large spaces between. Here the excavators found pottery sherds and coins that helped date the original construction. (Such a floor of ill-fitting stones enables us easily to understand the parable of the lost drachma in Luke 15:8.)

Museum of the Studium Biblicum Franciscanum



*An artist's reconstruction of the first century house that may have belonged to St. Peter. Like most houses of the early Roman period, it was a cluster of rooms structured around two courtyards. The center courtyard served as the family kitchen. Animals may have been kept in the other courtyard. The largest room of the house, delineated in black, later became the central hall of a house church. At that time, a two story arch was built inside the room to support an impressively high roof.*

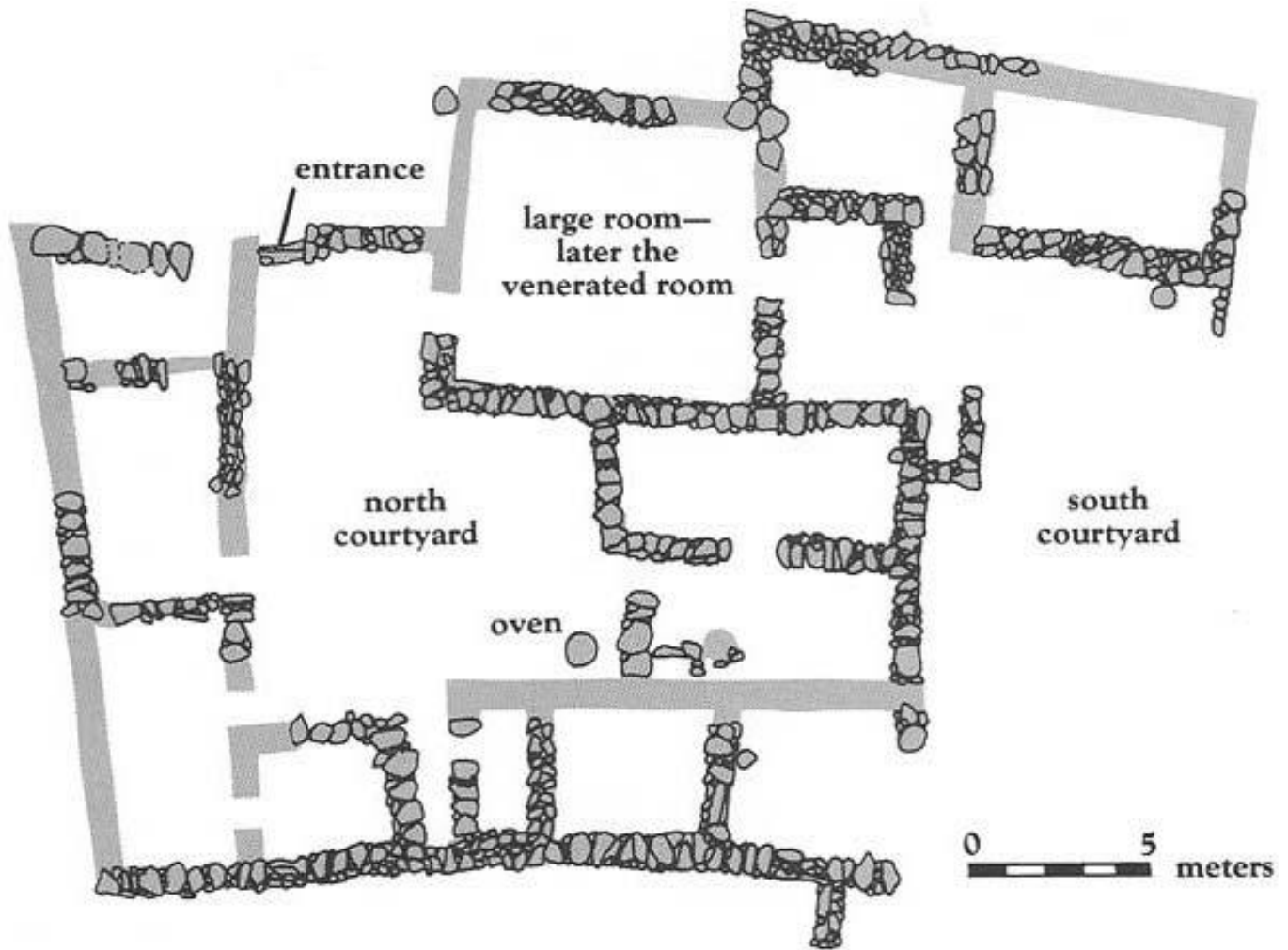

St. Peter's house at Capernaum (1st century A.D.).

The original house was organized around two interior courtyards, as was customary in the Roman period. The outside entrance on the east side opens directly into the north courtyard.

This courtyard was probably the main work area for the family that lived here. A round oven, where the family's food was no doubt prepared, was found in the southwest corner of this courtyard. This courtyard was surrounded by small rooms on the north and west. On the south was the largest room of the house. It was this room that later had the arch built into it so that its roof could be raised after the room became the central hall of the house-church. As originally built, the room had two entrances, one on the south and a second on the north. The room originally measured about 21 feet by 20 feet, a large room by ancient standards.

The southern door of this room led into the house's second courtyard. This courtyard may have been used for animals or for work areas associated with whatever house

industry was engaged in by the owners. Curiously enough, several fishhooks were found beneath one of the upper pavements from the later house-church, although this does not prove that the inhabitants of the original house were fishermen.

For all intents and purposes, this house as originally built is indistinguishable from all other houses of ancient Capernaum. Its indoor living area is somewhat larger than usual, but overall it is about the same size as other houses. Its building materials are the usual ones. It was built with no more sophistication than the others in the region. In short, there is nothing to distinguish this house from its neighbors, except perhaps the events that transpired there and what happened to it later.

During the second half of the first century A.D., someone did mark this house off from its neighbors. Perhaps as early as the middle of the first century A.D. the floor, walls, and ceiling of the single large room of the house were plastered. This was unusual in ancient Capernaum. Thus far, this is the only excavated house in the city with plastered walls. In the centuries that followed, the walls were re-plastered at least twice. The floor too was replastered a number of times.

The pottery used in the room also changed when the walls were plastered. The pottery that dates to the period before the walls were plastered is much like the pottery found in other houses designed for domestic use—a large number of cooking pots, bowls, pitchers, juglets, and a few storage jars. Once the room was plastered, however, we find only storage jars and the remains of some oil lamps.

The activities associated with the building obviously changed. No longer was the preparing and serving of food a major activity. Judging from the absence of bowls, people were no longer eating on the premises. The only activity that persisted was the storage of something in the large, two-handled storage jars of the period. Unfortunately, we cannot be sure what was stored. Within the thin layers of lime with which the floor was plastered and re-plastered, the excavators found many pieces of broken lamps.

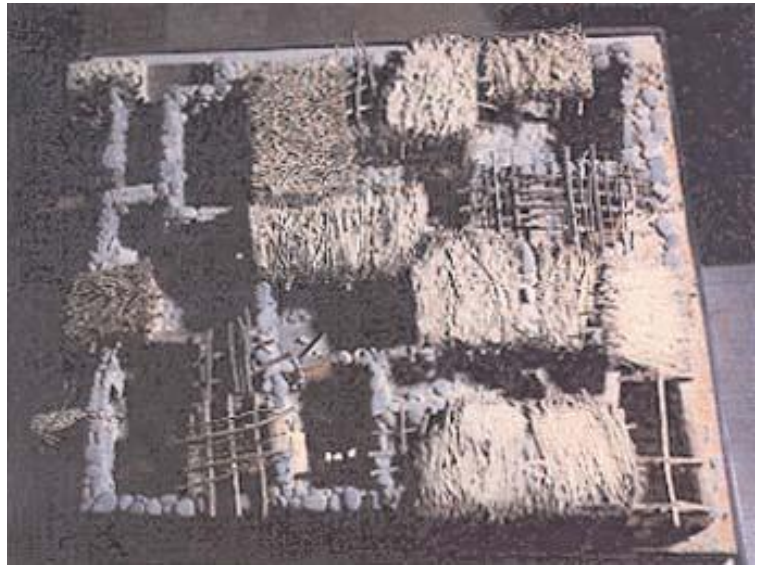

*Reconstruction of a first-century Capernaum house. This bird's-eye view shows a model of a house whose size, number of rooms, and building materials are all typical of houses built in Capernaum about 60 B.C. The simple stone walls of the one-story residence could not support a masonry roof. Instead, a crisscross of tree branches was used, augmented for some rooms with a mixture of earth and straw.*

Garo Nalbandian, courtesy Museum of the Studium Biblicum Franciscanum

At this time in early Roman history the only rooms that were plastered in such poor houses were important ones in which groups of people regularly gathered. Plaster provides a reflective surface and aids illumination. Both the plastering and the absence of pottery characteristic of family use combine to suggest that the room, previously part of a private home, was now devoted to some kind of public use. In view of the graffiti that mention Jesus as “Lord” and “Christ” (in Greek), it is reasonable to conclude, though cautiously, that this may be the earliest evidence for Christian gatherings that has ever come to light.

We have already referred to the fact that during the approximately 300 years that the building served as a so-called house-church, over a hundred graffiti were scratched on the plastered walls. These include, by our count, 111 Greek inscriptions, 9 Aramaic, 6 or perhaps as many as 9 Syriac in the Estrangelo alphabet,<sup>d</sup> 2 Latin, and at least 1 Hebrew inscription. Various forms of crosses, a boat, and perhaps a monogram, composed of the letters from the name Jesus, also appeared.

According to the Franciscan excavators, the name of St. Peter appears at least twice in these inscriptions. Many scholars are highly skeptical of these readings—and with good reason. Unfortunately, the scholarly publication of these very difficult inscriptions does not allow completely independent verification of the

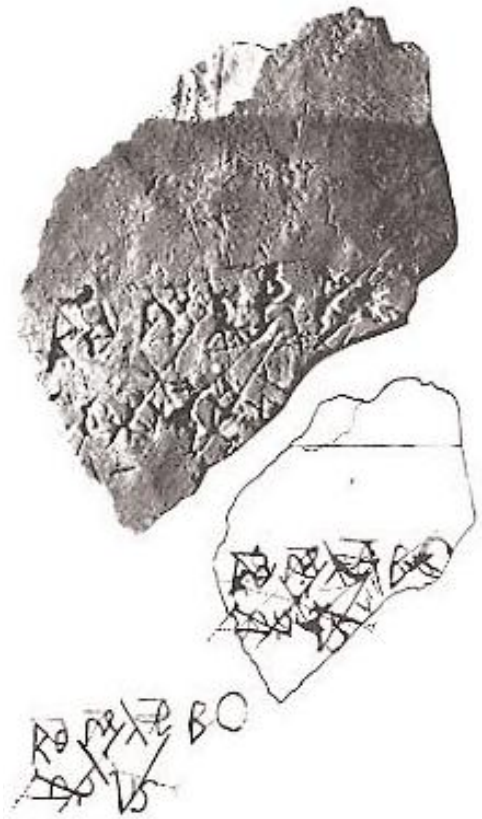

Courtesy Photographic Archive, Archaeological Expedition at Capernaum/Emmanuele Testa

A “St. Peter” graffito? The name “Peter” may appear in this “mare’s nest” of lines (top) scratched on a wall of the Capernaum house-church.

The drawing (center) is an exact reproduction of the inscription. It was made by Emmanuele Testa, epigrapher for the Franciscan expedition that excavated the building in the late 1960s. To the Franciscan excavators, the lines form the words “Peter, the helper of Rome,” but many scholars dispute this reading.

At bottom is another drawing made by Testa, this one an interpretation of the drawing of the “mare’s nest” of lines. The excavators read:

RO M AE BO ...  
PETR US

ROMAE is Latin for Rome; PETRUS, Latin for Peter; and BO(HQë,) Greek for helper.

Some scholars see two large X’s scratched over the inscription in an apparent effort to deface it. The strokes the excavators claim for “T” and “U” in the so-called “Peter” are, in fact, part of the two XX’s incised over the inscription. Also, the graffito shows horizontal marks above the groups of letters in the first line, indicating that these letter groups are Greek abbreviations. Thus, the meaning of the entire inscription is still a mystery.



excavators' conclusions because of the poor quality of the photographs. But even accepting the Franciscan expedition's drawings of what they see on these plaster fragments, there are still problems.<sup>6</sup>

Let us look more closely at these inscriptions allegedly referring to St. Peter. One, according to the excavators, is a Latin and Greek inscription that refers to "Peter, the helper of Rome." This of course would be astounding, if this is what it actually said. If we look at the photograph of the inscription, it is difficult to see anything more than a "mare's nest" of jumbled lines.

However, the epigrapher of the expedition, Emmanuele Testa, provides us with a drawing of the scratchings on the plaster fragment, which appears to be a faithful reproduction of what we called the "mare's nest."

From this, the epigrapher extracted in another line drawing what the excavators see—letters in an inscription.

The excavators see XV scratched over the underlying inscription. We see instead two large XX's apparently scratched over the inscription in an effort to deface it, but this is a small point. The excavators read the underlying inscription:

RO M AE BO ...  
PETR US

The first four letters of the name Peter (PETR), we are told, are in the form of a monogram—a cluster of letters. "Rome" is in Latin, as is "Petrus." BO is taken as a Greek word BO[HQDC] or some other Greek word from that root, meaning helper.

To the senior author of this article, the strokes which compose two of the letters of the name Peter, T (cocked to the right) and U (appearing as V in the drawing) are rather clearly part of the two XX's incised over the underlying inscription. So we are really left with pure ambiguity.

The word ROMAЕ is possible, but the MA does not look like anything at all to our eyes. Other readings are possible, especially because horizontal lines appear above the three groups of letters in the first line, which suggests that each of the three groups is a Greek abbreviation.

The excavators see a second reference to St. Peter in another graffito on a plaster fragment, this time in Latin but in Greek letters.

P            E            T            R            U            ,  
(Pi)        (Epsilon)    (Tau)        (Rho)        (Upsilon)    (Lunate Sigma)

The excavators' photograph and drawing of the fragment are printed together below.

The first letter (Pi) seems clear on the left. The last letter (C) is broken off at the end of the fragment. According to the excavators, the third, fourth, and fifth letters (Tau,

Rho and Upsilon) are combined in a monogram to form a cross, with another cross to the right. To the senior author of this article, however, critical elements in the putative monogram are part of two XX's defacing the underlying inscription, XX's similar to those in the other "Peter" inscription. Moreover, what the excavators see as a sigma appears rather clearly to be an omicron.

Even if these were references to the name Peter, they could well be references to pilgrims named Peter who wrote on these walls, rather than invocations of the name of St. Peter. For these reasons, we are skeptical of this alleged inscriptional support for identifying the original house as St. Peter's.

With what, then, are we left?

Was this originally St. Peter's house where Jesus stayed in Capernaum?

Reviewing the evidence, we can say with certainty that the site is ancient Capernaum. The house in question was located 84 feet south of the synagogue. Although the extant synagogue dates somewhere between the late second century and early fifth century, it is likely that an earlier synagogue stood on this same site.

The house in question was originally built in the late Hellenistic or early Roman period (about 60 B.C.). It was constructed of abundantly available, rough, black basalt boulders. It had a number of small rooms, two courtyards and one large room. When it was built, it was indistinguishable from all the other houses in the ancient seaside town.

Sometime about the middle of the first century A.D. the function of the building changed. It was no longer used as a house. Domestic pottery disappeared. The center room, including the floor, was plastered and replastered. The walls were covered with pictures. Only this center room was treated in this way. Christian inscriptions, including the name of Jesus and crosses, were scratched on the walls; some may possibly refer to Peter. Remnants of oil lamps and storage jars have been recovered. Fishing hooks have been found in between layers on the floor.



Courtesy Photographic Archive, Archaeological Expedition at Capernaum/Emmanuele Testa

Greek letters for "Peter." This inscription is one of a hundred scratched on the walls of the Capernaum building that served as a church from about the mid-first century through the fourth century A.D.

A drawing (below) shows the various marks on the plaster. The first letter on the left is clearly pi. The excavators also see the following letters: epsilon (E), tau (T), rho (R), upsilon (V) and lunate sigma (C). However, another interpretation is that the key strokes of these letters are really part of two XX's incised over the inscription, similar to the XX's in the other "Peter" graffito.

Even if one accepts the reading of "Peter," perhaps the inscription refers not to St. Peter, but to a pilgrim named Peter who visited the site sometime during these 300 years.

In a later century, two pilasters were erected on the north and south walls of this room; the lower parts of the pilasters have been found in the excavations. These pilasters supported a stone arch which in turn supported a new roof, no longer a light roof of branches, mud and straw, but a high masonry roof. On the eastern side of what had now become a house-church, an atrium was constructed in the fourth century about 27 feet long and 10 feet wide. Finally, a wall was built around the sacred compound.

This house-church survived into the mid-fifth century. Then precisely over the now plastered central room, an octagonal church was built, covering the same area and with the same dimensions. This was the kind of structure used to commemorate a special place in Christian history.

In addition, we know that as early as the fourth century, Christian pilgrims on visits to the site saw what they believed to be St. Peter's house. Sometime between 381 A.D. and 395 A.D. a Spanish nun named Egeria (Etheria) visited the site and reported in her diary that she had seen the house of St. Peter which had been turned into a church: "In Capernaum a house-church (*domus ecclesia*) was made out of the home of the prince of the apostles, whose walls still stand today as they were." A similar report appears in the diary of the anonymous sixth-century A.D. Italian traveler known as the Pilgrim of Piacenza. However, by this time the octagonal church had been constructed, so he refers to a church that had been built on the site: "We came to Capernaum to the house of St. Peter, which is now a basilica." Thus, even from this very early period, the site was associated with St. Peter's house.

Is this then the house of St. Peter? It cannot be confirmed—certainly not by inscriptions referring to St. Peter. But a considerable body of circumstantial evidence does point to its identification as St. Peter's house. Though we moderns search for proof, that hardly mattered to those ancient pilgrims who scratched their prayers on the walls of the house-church in the belief that this was, indeed, St. Peter's house. So, for that matter, what "proof" does a modern pilgrim need?

## Notes

- a. Capernaum is the Latinization of the Hebrew Kfar Nahum which means the village of Nahum.
- b. Tosephta.Megillah IV.23.
- c. A sacristy is a room or building connected with a religious house, in which the sacred vessels, vestments, etc., are kept.
- d. The Estrangelo alphabet is one of the most common of the Syriac alphabets. It probably first came into use in the first or second century A.D. and was most common in the third and fourth centuries A.D. Although its frequency then declined, it is still in use today.
- e. See *Cafarnao, Vol. IV (I graffiti della casa di S. Pietro)* by Emmanuele Testa (Jerusalem: Franciscan Printing Press, 1972); and James F. Strange "The Capernaum and Herodium Publications, Part 2, " *Bulletin of the American Schools of Oriental Research*, No. 233 (1979), pp. 68–69.

## How to Read the Plans

Plan adapted from Cafarnao I: Gli Edifici Della Citta (Franciscan Printing Press: 1975)

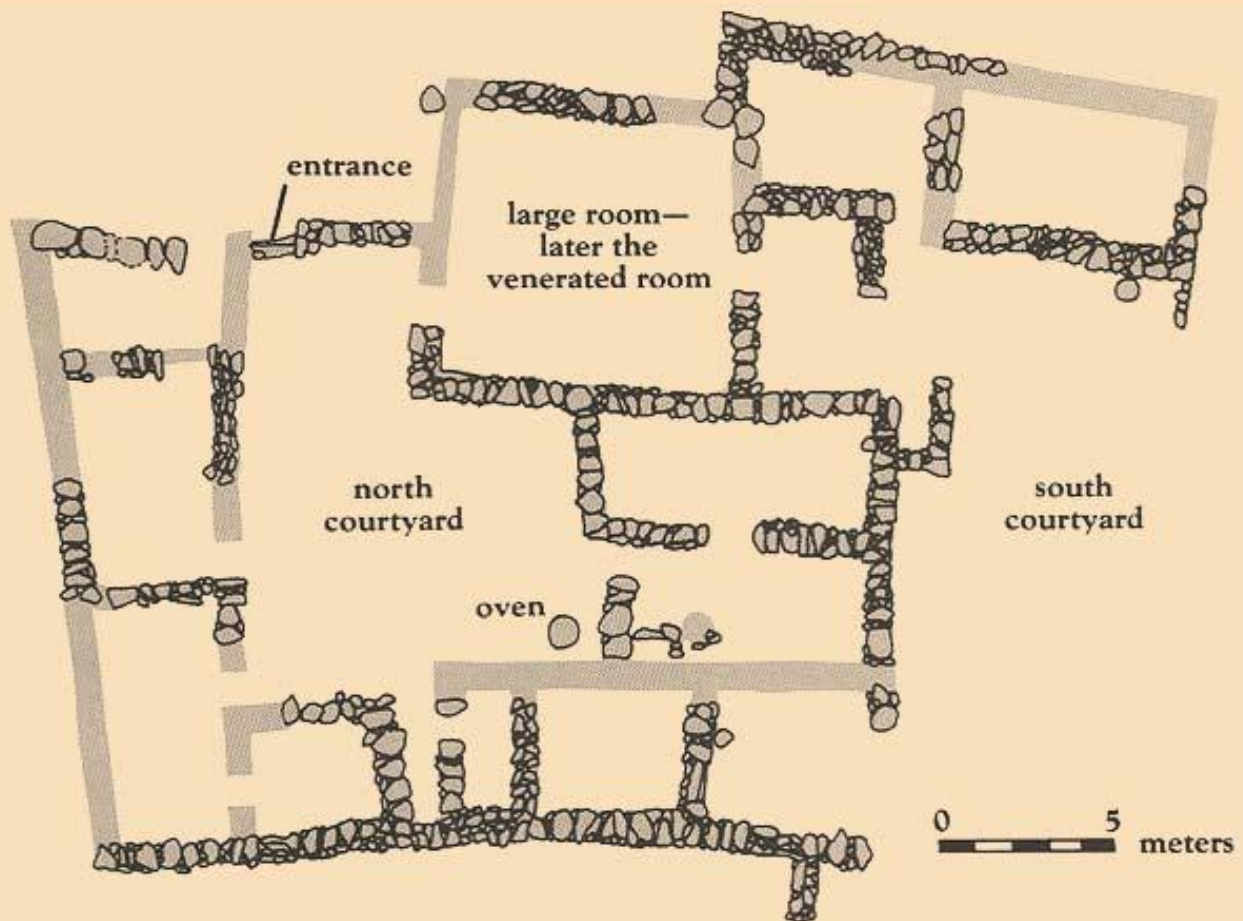

St. Peter's house at Capernaum (1st century A.D.).

These plans show the archaeological remains of structures from the first to the fifth centuries found at the site of St. Peter's House at Capernaum.

In the first century the simple house of Peter occupied the site. Later in the first century the central room of Peter's house became the venerated room of a house-church. In the fourth century, an arch-supported roof was constructed over the room and a wall was built around the entire complex. In the fifth century, the foundations of the venerated room lay beneath the center of a church composed of two complete concentric octagons and a third incomplete octagon; the innermost octagon included eight square pillars supporting arches which, in turn, supported a domed roof.

In the gray plan (top) we see the remains of the first century house of Peter. The dark blue plan (above) shows the remains of the fourth century house-church. The arrows in this plan point to the basalt piers on which rested a two-story arch supporting the roof over the venerated room. Many of the walls used in the first century continued in use in the fourth and, therefore, are visible in both plans.

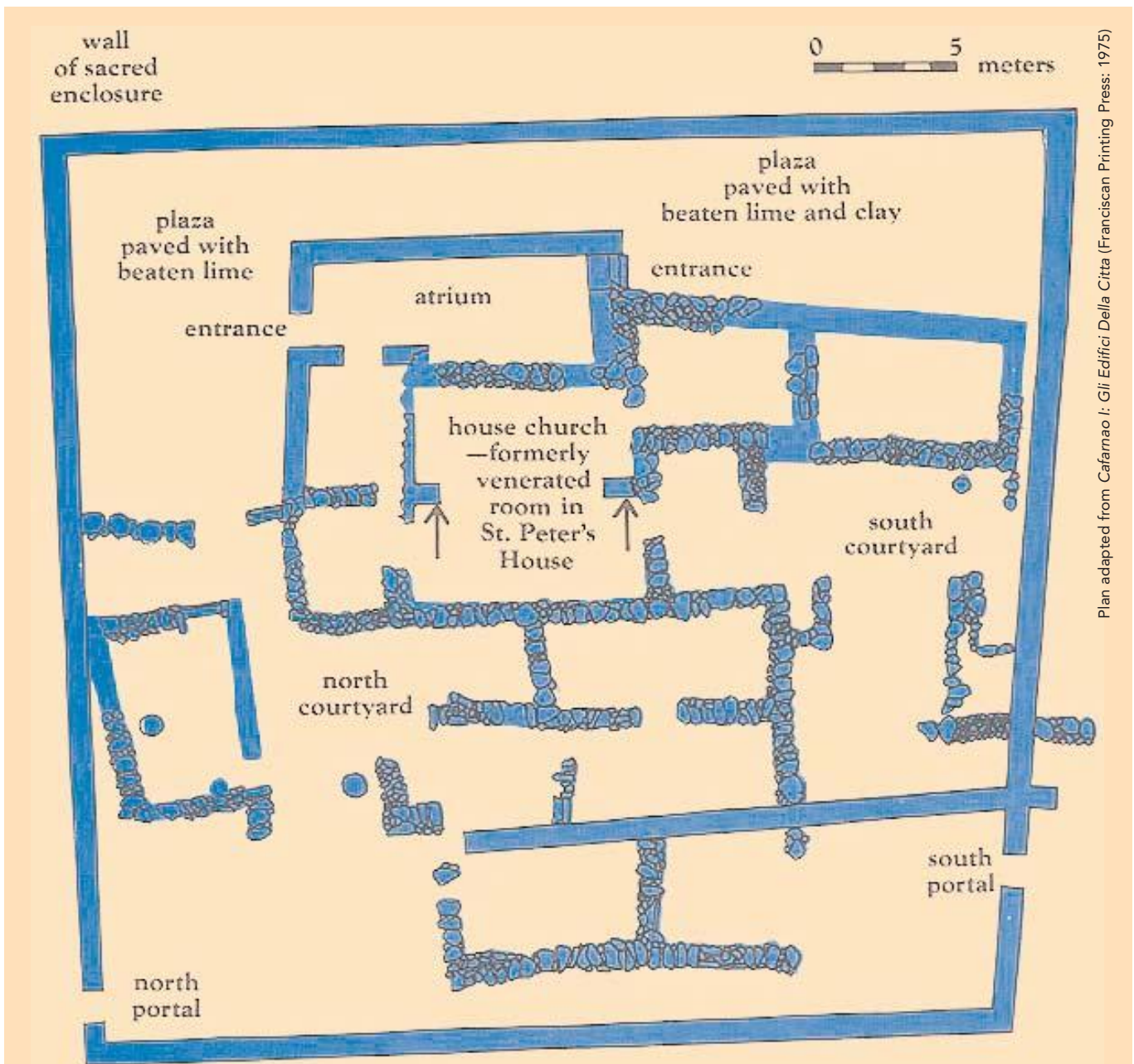

Plan adapted from Cafamao I: Gli Edifici Della Citta (Franciscan Printing Press: 1975)

*The house-church (4th century A.D.).*

In the plan above we see three layers of superimposed remains: gray is again used for structures from the first century; dark blue for structures added in the fourth century; and light blue for structures added in the fifth century. In order to see all the remains in use at each period it is necessary to look at the top plan for the first century, the second plan for the fourth century, and all walls enclosed in black lines in the plan above for the fifth century. The enclosure wall of the entire complex, although built in the fourth century, was also used in the fifth century. The plan above shows certain walls in gray which, although built in the first century, were also used in the fourth century (as can be seen in the second plan).

## The Galilee Jesus Knew

Plan adapted from Cafarnao I: Gli Edifici Della Citta (Franciscan Printing Press: 1975)

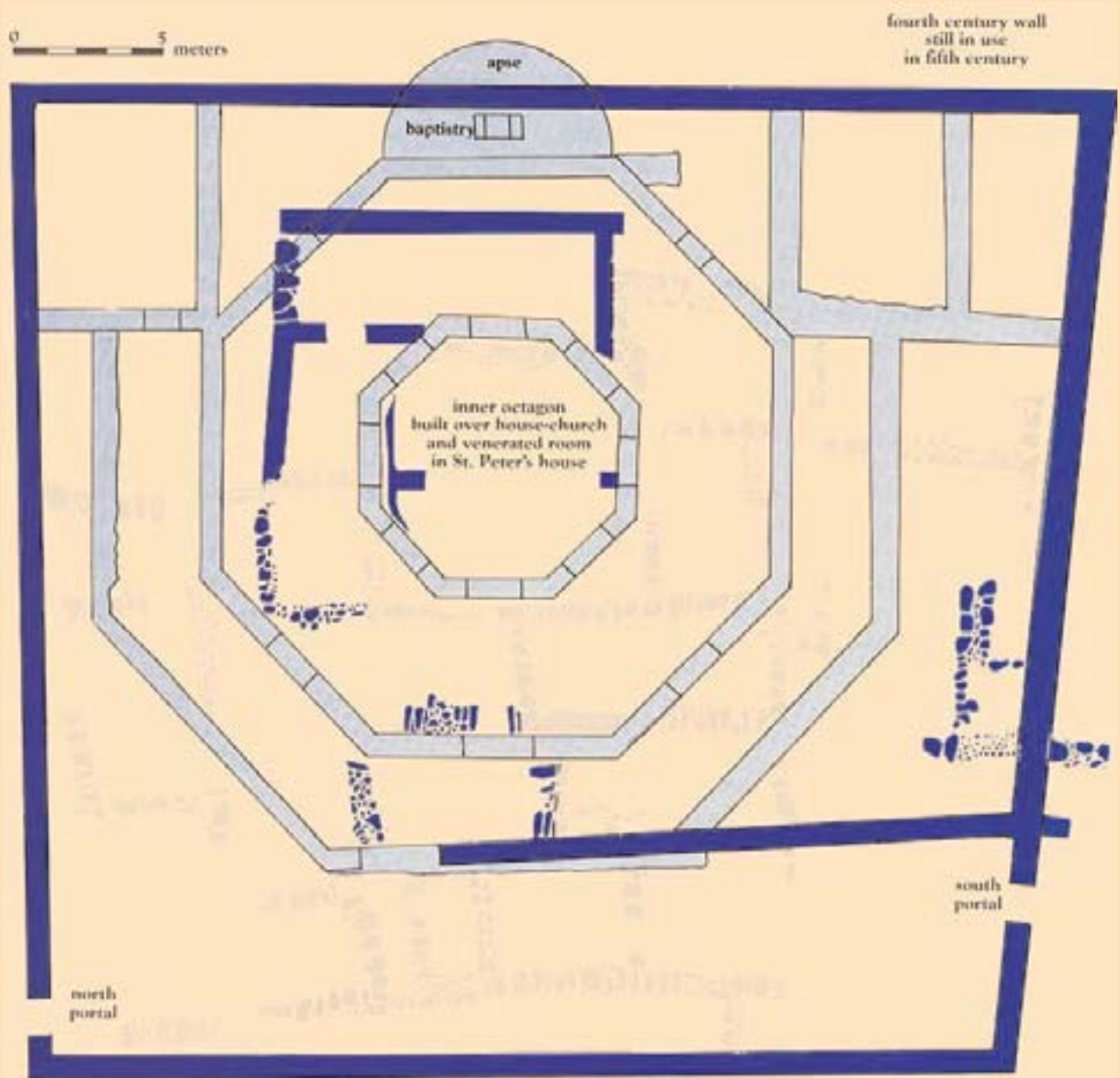

*The octagonal church (5th century A.D.), superimposed on 4th and 1st century remains.*